



A division of
WGI Westman Group Inc.



BRIDGE-PLATE[®]

Deep corrugated structural plate
for bridge, culvert and
tunnel applications.



BRIDGE-PLATE® |

BRIDGE-PLATE® is one of the strongest and deepest corrugated structural plate products on the market today, providing for the economical construction of long span soil-steel structures. Available in arch, ellipse, round and box-culvert shapes, structures are pre-engineered to make the selection process quick and easy. Standard spans range from 4m to 18m, with larger custom designs available. BRIDGE-PLATE is available with the Strata-CAT polymer coating system for added corrosion and abrasion protection.

TYPICAL APPLICATIONS

- Bridges
- Stockpile Tunnels
- Stream Crossing Enclosures
- Road or Rail Grade Separations
- Pipeline Crossings
- Structure Relines
- Mine Portals and Haul Roads
- Wildlife Crossings

Segmental Plate Construction

BRIDGE-PLATE Deep Corrugated Structural Plate Structures (DCSP) are assembled in the field using sectional pre-curved plates bolted together and backfilled with compacted, well graded granular material. The engineered backfill provides structural stability and completes the installation of the BRIDGE-PLATE steel shell. The interaction of a well compacted engineered backfill with the superior sectional properties of BRIDGE-PLATE ensures a structure capable of supporting high loads with the most economical use of steel. With installation time measured in weeks rather than months, road closure periods are shortened and disruption to environmentally sensitive locations is minimized. Choosing a BRIDGE-PLATE buried soil-steel structure eliminates the bridge deck, approach slabs and expansion joints common in traditional bridge design, significantly reducing maintenance and total life cycle costs.



VARIETY OF SHAPES

- Single radius arch, high and low profile arch, full periphery, box culvert and custom shapes available



TRANSPORTATION EFFICIENCY

- Delivered to the job site in nested bundles for economical transportation



LOAD-CARRYING CAPACITY

- Deep corrugated profile provides superior strength and stiffness allowing the structure to withstand heavy loads



EASE OF INSTALLATION

- Installation time measured in weeks rather than months, saving overall construction costs and improving productivity

With the introduction of the first structural plate product in 1931, Armtec has led the way in the development of corrugated soil-steel structures. We are committed to providing our customers with the most economical and durable bridge solutions available.



SHAPES

BRIDGE-PLATE is available in a variety of shapes. Armtec can assist in shape and geometry selection based on project requirements for optimum span-to-rise ratio, clearance box analysis, cover height requirements and plate thickness. Custom shapes and configurations are also available from Armtec.

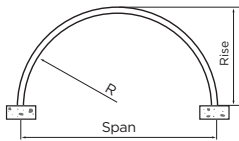

SINGLE RADIUS ARCH: This shape is commonly used for bridges, stream enclosures, culverts and stormwater drains. Its open-bottom configuration makes it 'fish-friendly', minimizing disruption to the aquatic habitat and maintaining the natural stream bed. It is ideal for medium to high fills.

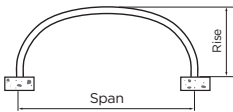

LOW PROFILE ARCH: The low profile arch shape is ideal for bridges and underpasses where overhead clearance is limited. It also maintains the natural stream bed.

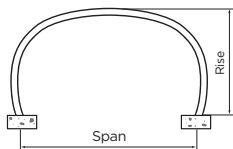

HIGH PROFILE ARCH: This shape is suitable for locations where headroom is not limited, including large span projects. It is often used for highway grade separation, railway underpasses and mine portals.

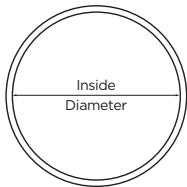

ROUND: The round shape is suitable for culverts and stormwater drains as well as vehicular and pedestrian tunnels.

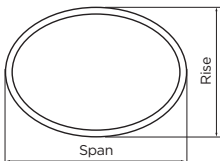

ELLIPTICAL: This shape is commonly used for vehicle and railway underpasses or service tunnels. Horizontal ellipses are best suited for multi-lane traffic and vertical ellipses are better for railway underpasses which require greater headroom.

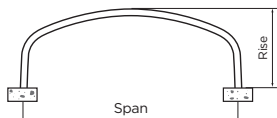

BOX CULVERT: This design optimizes clearance box and flow geometry, while maintaining superior strength and low cover requirements. It is suitable for low, wide bridges, culverts and stream crossings.



BRIDGE-PLATE Deep Corrugated Plate pushes the span of structural plate products to over 20 metres.

BRIDGE-PLATE PROPERTIES

Corrugation Profile 400 x 150mm

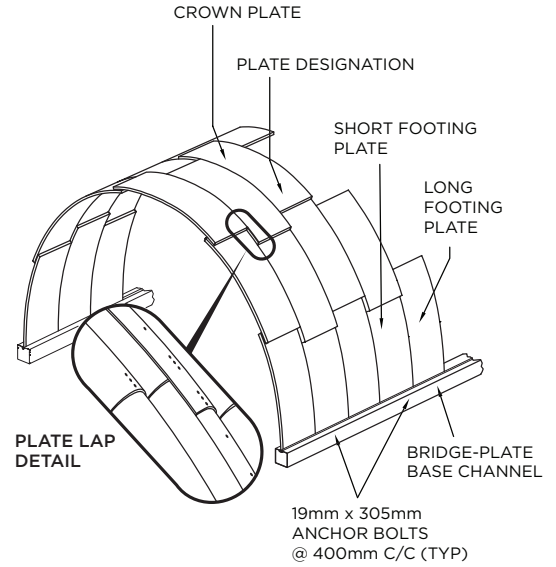
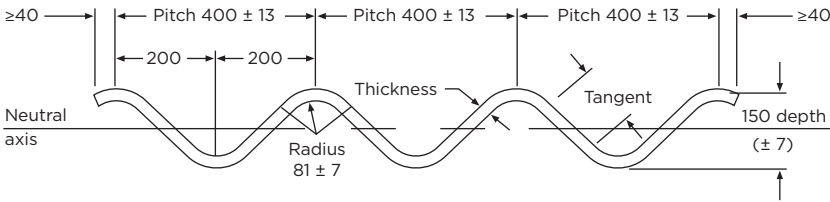

Table 1: Section properties of Armtec BRIDGE-PLATE

Nominal Thickness (mm)	Design Thickness (mm)	Tangent Length (mm)	Angle θ (degrees)	Area of Section (mm ² /mm)	Moment of Inertia (mm ⁴ /mm)	Elastic Section Modulus (mm ³ /mm)	Plastic Section Modulus (mm ³ /mm)	Radius of Gyration (mm)
4.3	4.21	112.41	51.29	5.792	16,187	200.52	273.62	52.86
5.0	4.95	111.42	51.44	6.811	19,060	235.04	321.70	52.90
6.0	6.00	110.00	51.64	8.260	23,154	283.71	390.57	52.95
7.0	7.00	108.63	51.84	9.640	27,071	329.69	456.35	52.99
8.0	7.94	107.33	52.03	10.940	30,759	372.48	518.88	53.04

BRIDGE-PLATE is manufactured in an ISO 9001:2008 certified plant and meets CSA Group Standard G401-14.

Table 2: BRIDGE-PLATE dimensions

Plate Length H (425mm)	Net Length (mm)	Overall Length (mm)
4	1,700	1,980
5	2,125	2,405
6	2,550	2,830
7	2,975	3,255
8	3,400	3,680
9	3,825	4,105

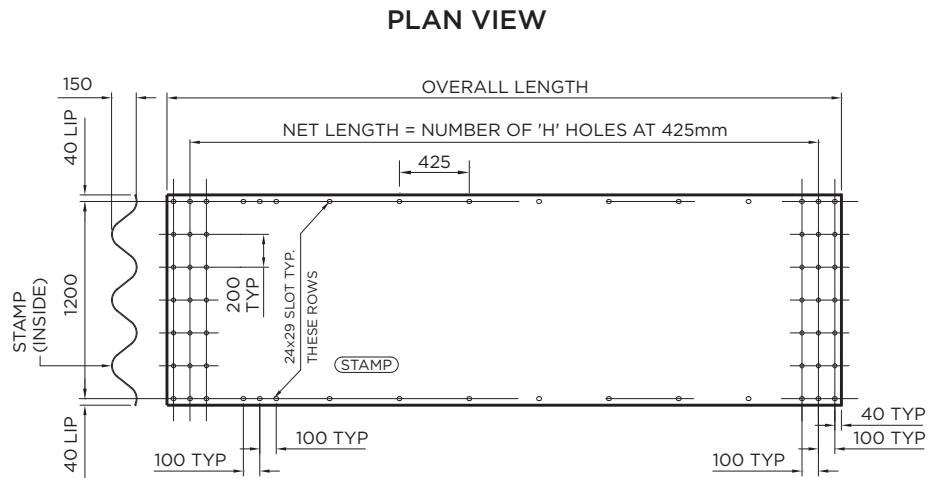

DESIGN STANDARD

Structural Design

Armtec uses a state-of-the-art computer program to analyze and design BRIDGE-PLATE structures. Other widely accepted design methods may also be used, including:

- CAN/CSA S6 Canadian Highway Bridge Design Code (CHBDC)
- Soil-Culvert Interaction Method (SCI, by Duncan)
- American Society for Testing and Materials (ASTM) Standard Specifications
- American Association of State and Highway Transportation Officials (AASHTO) Standard Specifications

Buried Structures (Section 7) of the Canadian Highway Bridge Design Code (CAN/CSA S6) addresses the analysis and design of soil-metal structures and soil-metal box structures. It has become the recognized design standard for soil-steel structures in Canada. The CHBDC method is based upon the Limit States Design philosophy and supersedes the Ontario Highway Bridge Design Code (OHBDC) and the older CAN/CSA-S6-88 "Design of Highway Bridges" Standard.

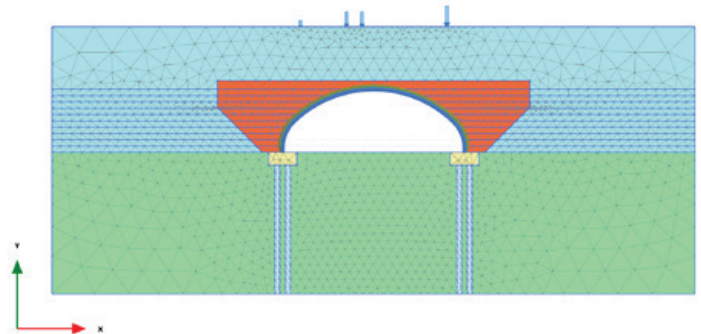

ARMTEC'S FINITE ELEMENT ANALYSIS FOR BRIDGE-PLATE DESIGN

NOTE:

- Our Region Engineers and Sales Representatives, with technical support from our Engineering Department, are trained to work with you on economical solutions to your design challenges
- Some highway departments may have their own design criteria
- BRIDGE-PLATE technical details, including design examples, are available in the Corrugated Steel Pipe Institute (CSPI) Handbook



SUPERIOR PLATE STIFFNESS AND BENDING PROPERTIES MAKES BRIDGE-PLATE STAND UP TO THE RIGORS OF INSTALLATION



CURVED BRIDGE-PLATE INSTALLATION



HIGHWAY 401 KINGSTON, ONTARIO - QUICK INSTALLATION REDUCES DISRUPTION TO ROAD USERS

FOOTINGS

BRIDGE-PLATE arches are typically installed on concrete strip footings. Receiving angles and anchor bolts are supplied, complete with detailed layout instructions, for casting into the footings. Armtec will provide unfactored footing load values and can also assist with preliminary footing sizing. Corrugated steel footings (for box culverts) and precast footings are also options designed and supplied by Armtec depending on specific site foundation conditions and design loads.

Footings:

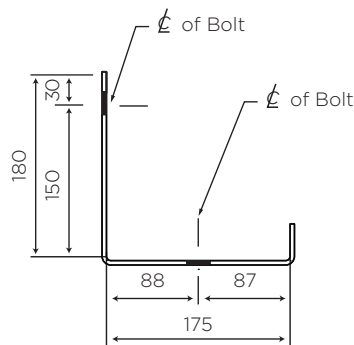
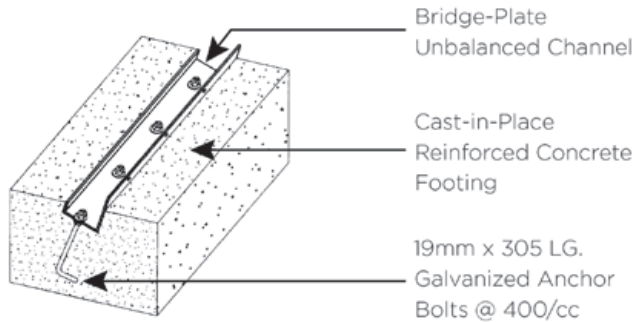

BOX CULVERT WITH STEEL FOOTINGS



BOX CULVERT WITH PRECAST FOOTINGS

COATINGS

Armtec BRIDGE-PLATE is available in a number of material and coating options to accommodate different environmental parameters and design service life (DSL) requirements. BRIDGE-PLATE components are hot-dip galvanized in accordance with CSA Standard G164 to provide a durable and corrosion resistant coating. This coating can be supplied in different thicknesses.

For extended service life and performance, **Strata-CAT** coating provides a two-coat polymer coating system. The base coat is a zinc-rich layer providing outstanding corrosion resistance while the top coat polymer layer provides superior resistance to impact, corrosion, abrasion and diluted inorganic acid or alkali. The **Strata-CAT** system is designed to provide a service life between 75 and 100 years, depending on environmental parameters.



STRATA-CAT CORROSION PROTECTION EXTENDS SERVICE LIFE TO 75+ YEARS

FOR MORE INFORMATION ON ARMTEC'S STRATA-CAT COATING,
PLEASE SEE OUR STRATA-CAT PRODUCT GUIDE.

END TREATMENTS

Armtec recommends the use of a concrete collar around each end of a BRIDGE-PLATE structure. This serves to stiffen the ends, protecting them from localized damage and deformation, while improving their structural integrity. Square or beveled ends are available on standard structures. Alternate end treatments, such as MSE wire mesh face, Bin-Wall and steel face tie-back walls can be considered when access to concrete is limited. For water crossings the addition of an impervious headwall protects the structure against piping and erosion, and provides for enhanced entrance hydraulics.



CAST-IN-PLACE HEADWALL WITH SEGMENTAL BLOCK RETAINING WINGWALLS



ROCK FACE WIRE MESH WITH MECHANICALLY STABILIZED EARTH (MSE) RETAINING WALLS



CAST-IN-PLACE CONCRETE HEADWALLS WITH ARMTEC BIN-WALLS



SEGMENTAL BLOCK-END WALLS



ARMTEC SHEETING HEADWALL



BRIDGE-PLATE HEADWALL AND BIN-WALL WINGWALLS



CAST-IN-PLACE CONCRETE HEADWALLS



GEOCELL MSE RETAINING WALLS



GABION HEADWALLS

Armtec Design-Build Services

Armtec provides complete engineering design services for BRIDGE-PLATE structures and accompanying products. Provide us with your requirements and let us do the rest! Our experienced engineers will develop a custom solution, tailored to meet your project needs.

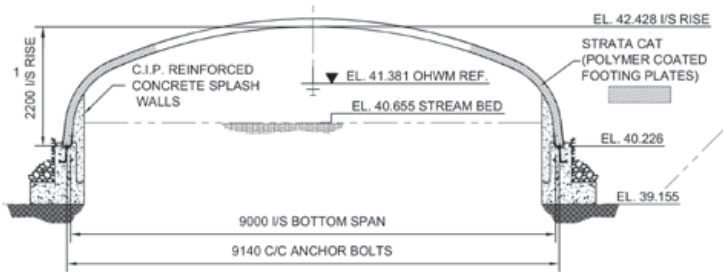
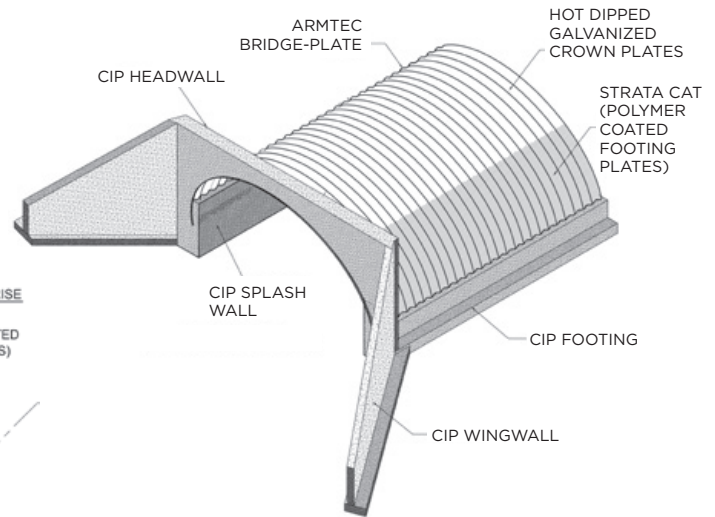

Today Armtec engineering experience and design services allow designers to tackle applications utilizing buried steel structures where few other economical solutions exist.

Once a design is approved, each BRIDGE-PLATE structure is custom built to the highest standard of quality in our manufacturing facility. From there, quality checks ensure there will be no surprises in the field.

In addition to the BRIDGE-PLATE structure, Armtec engineers can assist with a full system design including footings and end treatments as well as supply a wide range of construction materials.

Our involvement doesn't stop there. An Armtec field representative is available to provide support during the construction phase. Let us partner with you on your next project - **we strive to see your vision built!**

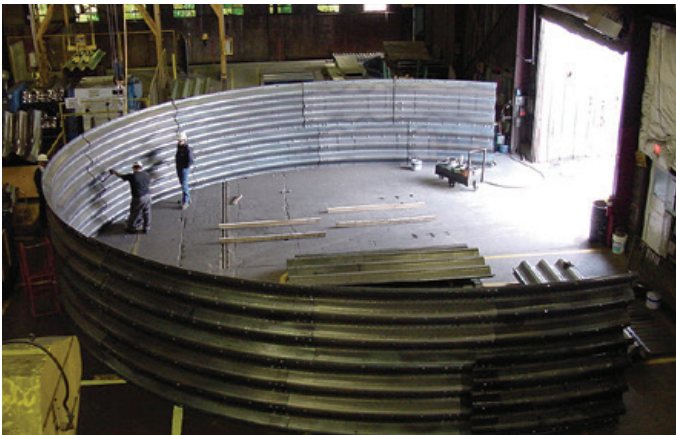

PLANT ASSEMBLY OF TWO FULL RINGS ENSURES EASE OF INSTALLATION IN THE FIELD



INSTALLATION

Typical of engineered structures, proper installation is critical to ensure long-term, maintenance-free, performance of the structure. In practical terms, installation can be broken into **3 major operations**.

1. Foundation Preparation

Since BRIDGE-PLATE structures are typically installed on concrete strip footings, receiving angles and anchor bolts are supplied, complete with detailed layout instructions for casting into the footings. Armtec will provide unfactored footing load values for design of the concrete footings. Corrugated steel footing pads may also be an option for box culverts, depending on specific site conditions and local requirements.

Footings are to be built square and parallel to a gauge or control line. The unbalanced channels supplied by Armtec must be installed to the correct line and grade in the concrete footings. The line and grade of the finished concrete footings must be checked before plate assembly begins. The start and end of the unbalanced channels should be clearly marked on the footings.



ASSEMBLY OF BRIDGE-PLATE SECTIONS IS QUICK AND EASY

2. Assembly and Installation

BRIDGE-PLATE structures are pre-assembled at the manufacturing plant as a quality assurance measure. Typically a single ring is constructed to ensure the assembled shape meets all design specifications. BRIDGE-PLATE components are then delivered to the job site in nested bundles which are easily sorted prior to site assembly. Hardware is shipped in separate containers.

1. Initially two full rings are pre-assembled near the site. After sitting the rings onto the footing, plate assembly proceeds with either individual plates or sub-assembled arcs.

2. The assembly method employed depends on the structure type and site considerations. Sections can be sub-assembled near the excavation and lifted into place for final assembly, or structures may be assembled in place, plate by plate.

3. Alternative methods are also available.

Typical Assembly Tools

- Spud wrenches
- Clevises
- Cables and slings for lifting
- Air impact tools
- Turnbuckles
- Eyebolts
- Alignment pins, pry-bars



BRIDGE-PLATE INSTALLATION TIME IS MEASURED IN WEEKS RATHER THAN MONTHS

3. Backfill and Compaction

The structural success of BRIDGE-PLATE depends on the interaction of the backfill material and the steel shell. The selection, placement and compaction of the engineered backfill material is a key element in the performance of a soil-steel structure. As a principle rule for backfilling, approved granular materials should be used to construct an engineered backfill envelope. It should be placed in maximum 200mm lifts to ensure that specified compaction levels are attained.

Backfill Guidelines

- Material is placed loose in 200mm lifts
- Backfill is to be compacted to 95% Standard Proctor Dry Density
- Backfill to be compacted at optimum moisture content
- Lifts to be placed in a balanced manner on both sides of structure
- No more than 400mm difference in top of backfill elevation from side to side of structure
- First 600mm above structure to be lightly compacted (walk-behind equipment)
- First 1.5m above structure to be spread using small (typically D4) equipment
- Large vibratory equipment to be kept at least 1.5m away from walls of structure
- Dimensions of critical backfill zone are as per Armtec drawings

Typical Equipment Required for Backfilling in Critical Backfill Zone

- Excavator(s) with adequate reach to place backfill
- Small tracked/wheeled equipment for spreading
- Walk-behind compactor
- Vibrating plate tampers
- Ride-on compactor up to 15 tonnes for larger areas (not permitted within 1.5m of structure)
- Water truck or water supply
- Hand tools as appropriate

Table 3: Backfill particle size range

Sieve Size	% Passing	% Retained
75	100	0
50	60-98	2-40
37.5	47-96	4-53
19	33-90	10-67
9.5	22-82	18-78
4.75 - No.4	15-72	28-85
2.36 - No.8	10-60	40-90
1.18 - No.16	8-45	55-92
0.3 - No.50	4-18	82-96
0.15 - No.100	0-10	90-100
.075 - No.200	0-5	95-100

NOTE:

- See Armtec backfill drawings for complete instructions
- Material to be granular with angular grains
- Sieve analysis to fall within the stated envelope
- Material to be well graded - uniform, skip or gap grading is not permitted

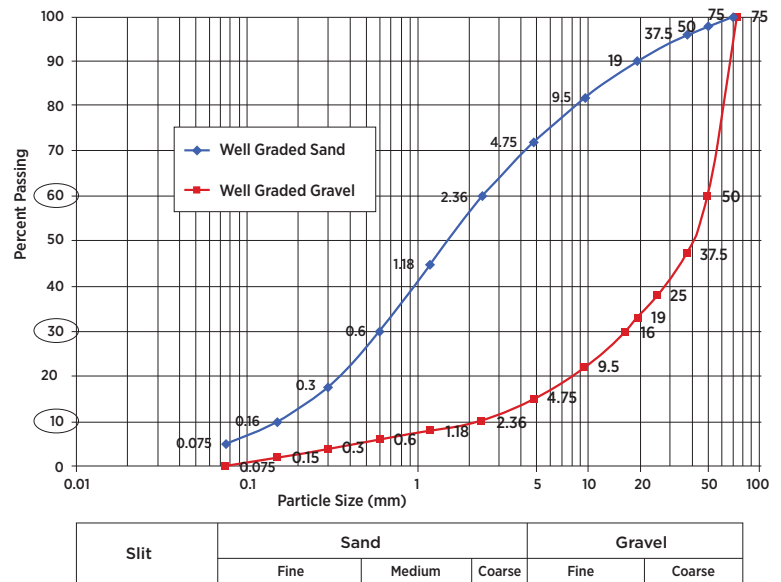

Additional sizes are available for all **BRIDGE-PLATE** structures. **Contact us to find out more.**

Table 4: Single radius arch technical data

Span	Rise	Periphery	End Area	Radius
mm	mm	H	m ²	mm
6,000	2,985	22	14.05	3,000
6,500	3,267	24	16.70	3,250
7,000	3,548	26	19.58	3,500
7,500	3,830	28	22.69	3,750
9,000	4,465	33	31.51	4,500
9,250	4,610	34	33.44	4,625
9,500	4,750	35	35.43	4,750
9,750	4,890	36	37.47	4,875
10,000	5,030	37	39.57	5,000
10,250	5,170	38	41.73	5,125
10,500	5,310	39	43.95	5,250
10,750	5,455	40	46.22	5,375
11,000	5,595	41	48.55	5,500
11,250	5,735	42	50.94	5,625
11,500	5,665	42	50.97	5,750
11,750	5,805	43	53.42	5,875
12,000	5,950	44	55.93	6,000
12,250	6,090	45	58.49	6,125
12,500	6,230	46	61.11	6,250
12,750	6,370	47	63.79	6,375
13,000	6,510	48	66.52	6,500
13,250	6,655	49	69.31	6,625
13,500	6,795	50	72.16	6,750
13,750	6,935	51	75.07	6,875
14,000	7,075	52	78.03	7,000
14,250	7,215	53	81.05	7,125
14,500	7,360	54	84.13	7,250
14,750	7,500	55	87.26	7,375
15,000	7,430	55	87.60	7,500
15,250	7,570	56	90.49	7,625
15,500	7,710	57	93.75	7,750
15,750	7,850	58	97.06	7,875
16,000	7,995	59	100.43	8,000

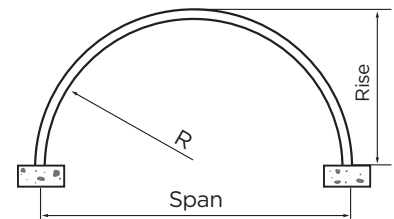

ST. KITTS - COMPONENTS ARE SHIPPED IN NESTED BUNDLES FOR ECONOMICAL TRANSPORTATION

NOTE:

- Other sizes are available, please contact an Armtec representative
- H = 425mm (spacing between periphery holes)
- Span, rise and end area measurements are based on inside dimensions

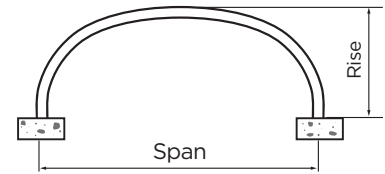

Table 5: Low-profile arch BRIDGE-PLATE technical data

Structure Ref.	Periphery	Span	Rise	Bottom Span	Re-entrant Angle	End Area	Span/Rise
	H	mm	mm	mm	°	m ²	
12H5	22	6,191	2,784	6,160	6.80	13.883	2.22
13H5	23	6,577	2,857	6,546	6.86	15.114	2.30
14H5	24	6,964	2,930	6,932	6.92	16.384	2.38
16H5	26	7,740	3,075	7,707	7.00	19.042	2.52
17H5	27	8,128	3,148	8,095	7.04	20.428	2.58
17H6	29	8,414	3,529	8,368	7.61	23.872	2.38
18H5	28	8,516	3,221	8,483	7.07	21.854	2.64
18H7	32	9,087	3,983	9,028	8.07	29.203	2.28
19H5	29	8,905	3,293	8,871	7.10	23.319	2.70
20H5	30	9,294	3,366	9,260	7.13	24.822	2.76
21H6	33	9,967	3,820	9,920	7.72	30.402	2.61
22H6	34	10,356	3,892	10,309	7.75	32.131	2.66
23H5	33	10,489	3,569	10,457	6.91	29.512	2.94
23H7	37	11,063	4,331	11,006	7.90	38.361	2.55
24H5	34	10,878	3,641	10,845	6.94	31.167	2.99
24H7	38	11,451	4,403	11,394	7.93	40.313	2.60
25H5	35	11,266	3,714	11,234	6.96	32.861	3.03
25H7	39	11,840	4,476	11,782	7.96	42.304	2.65
26H7	40	12,228	4,548	12,170	7.99	44.333	2.69
27H8	43	12,974	4,995	12,926	6.70	51.680	2.60
28H8	44	13,362	5,067	13,314	6.72	53.933	2.64
29H8	45	13,751	5,140	13,702	6.74	56.225	2.68
30H8	46	14,139	5,212	14,090	6.76	58.555	2.71
31H9	49	14,813	5,667	14,752	7.20	66.963	2.61
32H9	50	15,202	5,739	15,140	7.21	69.520	2.65
33H9	51	15,590	5,812	15,528	7.23	72.115	2.68
33H11	55	16,160	6,575	16,072	7.85	85.281	2.46

NOTE:

- Other sizes are available, please contact an Armtec representative
- H = 425mm (spacing between periphery holes)
- Span, rise and end area measurements are based on inside dimensions

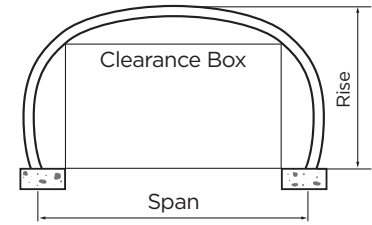

Table 6: High-profile arch BRIDGE-PLATE technical data

Structure Ref.	Periphery	Span	Rise	Bottom Span	Re-entrant Angle	End Area	Span/Rise
	H	mm	mm	mm	°	m ²	
20HS4	28	5,934	4,255	5,642	15.16	21.31	1.39
20HS6	32	5,989	5,097	5,563	15.06	26.30	1.18
22HS5	32	6,553	4,930	6,191	15.16	27.44	1.33
22HS7	36	6,607	5,773	6,110	15.09	32.95	1.14
23HS5	33	6,952	5,029	6,611	15.01	29.54	1.38
23HS8	39	7,051	6,293	6,521	14.87	38.38	1.12
24HS6	36	7,280	5,578	6,878	14.88	34.56	1.31
24HS8	40	7,344	6,420	6,809	14.95	40.70	1.14
25HS9	43	7,670	6,969	7,072	14.89	46.31	1.10
26HS6	38	7,869	5,831	7,459	15.01	38.89	1.35
26HS9	44	7,963	7,095	7,361	14.95	48.87	1.12
27HS6	39	8,163	5,958	7,751	15.06	41.14	1.37
27HS9	45	8,257	7,222	7,650	15.01	51.49	1.14
28HS6	40	8,458	6,085	8,042	15.12	43.45	1.39
28HS7	42	8,489	6,507	8,014	14.97	47.01	1.30
28HS10	48	8,582	7,771	7,911	14.96	57.77	1.10
29HS7	43	8,784	6,634	8,306	15.02	49.50	1.32
29HS10	49	8,876	7,897	8,200	15.01	60.62	1.12
30HS7	44	9,078	6,760	8,597	15.06	52.05	1.34
30HS10	50	9,169	8,024	8,490	15.05	63.54	1.14
31HS7	45	9,373	6,887	8,889	15.11	54.65	1.36
31HS8	47	9,404	7,309	8,859	15.00	58.60	1.29
32HS9	50	9,730	7,857	9,120	14.95	65.48	1.24
33HS7	47	9,966	7,142	9,493	14.83	60.06	1.40
33HS9	51	10,024	7,984	9,412	14.99	68.44	1.26
34HS8	50	10,288	7,689	9,735	15.11	67.13	1.34
37HS8	53	11,176	8,071	10,632	14.90	76.20	1.38

NOTE:

- Other sizes are available, please contact an Armtec representative
- H = 425mm (spacing between periphery holes)
- Span, rise and end area measurements are based on inside dimensions

Table 7: Round BRIDGE-PLATE technical data

Diameter	Periphery	End Area
mm	H	m ²
6,075	46	28.97
6,345	48	31.60
6,615	50	34.36
6,885	52	37.23
7,155	54	40.21
7,425	56	43.31
7,695	58	46.52
7,965	60	49.85
8,235	62	53.29
8,510	64	56.85
8,780	66	60.53
9,050	68	64.31
9,320	70	68.22
9,590	72	72.24
9,860	74	76.37
10,130	76	80.62
10,400	78	84.98
10,675	80	89.46
10,945	82	94.05
11,215	84	98.76
11,485	86	103.58
11,755	88	108.52
12,025	90	113.58
12,295	92	118.74
12,565	94	124.03
12,835	96	129.43
13,110	98	134.94
13,380	100	140.57
13,650	102	146.31
13,920	104	152.17
14,190	106	158.14
14,460	108	164.23
14,730	110	170.43
15,000	112	176.75
15,270	114	183.18
15,545	116	189.73
15,815	118	196.40

NOTE:

- Other sizes are available, please contact an Armtec representative
- H = 425mm (spacing between periphery holes)
- Span, rise and end area measurements are based on inside dimensions

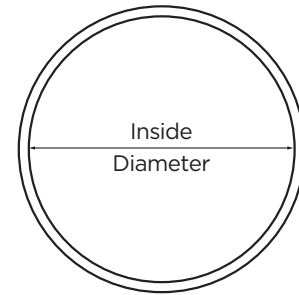

FISH FRIENDLY AND COST-EFFECTIVE BRIDGE-PLATE FOR BC MOT

When a failing structure required replacement in an environmentally sensitive aquatic habitat, BRIDGE-PLATE provided an economical, ‘fish-friendly’ solution. The old structure was disassembled above the waterline and used as a temporary flume with rocks added to create resting areas for the fish. Thanks to one of the stiffest corrugation profiles in the industry, BRIDGE-PLATE was assembled without the need for internal support from sizing cables or struts, minimizing disturbance to the creek running continuously below the arch structure.



McDONALD CREEK IS ONE OF THE MOST IMPORTANT FISH STREAM HABITATS IN THE ARROW LAKE, B.C. WATER-SHED

For vertical ellipse data please contact an Armtec representative.

Table 8: Ellipse BRIDGE-PLATE technical data

Span	Rise	Periphery	Inside End Area
mm	mm	H	m ²
8,807	6,415	58	44.89
8,981	6,891	60	48.48
9,058	6,179	58	43.93
9,155	7,264	62	52.18
9,198	6,660	60	47.84
9,329	7,637	64	55.96
9,372	7,033	62	51.58
9,546	7,406	64	55.42
9,590	6,802	62	50.87
9,720	7,779	66	59.35
9,764	7,175	64	54.76
9,894	8,152	68	63.37
9,938	7,548	66	58.74
9,981	6,945	64	53.97
10,112	7,922	68	62.81
10,155	7,318	66	58.01
10,286	8,295	70	66.98
10,329	7,691	68	62.14
10,372	7,087	66	57.15
10,460	8,668	72	71.23
10,503	8,064	70	66.36
10,546	7,460	68	61.33
10,677	8,437	72	70.67
10,720	7,833	70	65.61
10,764	7,230	68	60.41
10,851	8,810	74	75.07
10,894	8,206	72	69.97
10,938	7,603	70	64.74
11,025	9,183	76	79.56
11,068	8,579	74	74.43
11,112	7,976	72	69.16
11,155	7,372	70	63.75
11,242	8,653	76	78.98
11,286	8,349	74	73.67
11,329	7,745	72	68.22
11,416	9,326	78	83.62
11,460	8,722	76	78.28
11,503	8,118	74	72.79
11,546	7,514	72	67.16
11,560	7,980	74	72.36
11,634	9,095	78	82.97
11,677	8,491	78	77.44
11,720	7,888	74	71.77
11,808	9,468	80	87.75
11,851	8,864	78	82.19
11,894	8,261	76	76.49
11,938	7,657	74	70.64
12,025	9,237	80	87.03
12,068	8,634	78	81.29
12,112	8,030	76	75.41

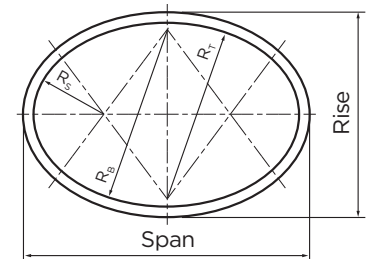

Span	Rise	Periphery	Inside End Area
mm	mm	H	m ²
12,199	9,610	82	91.96
12,242	9,007	80	86.19
12,286	8,403	78	80.27
12,329	7,799	76	74.20
12,416	9,380	82	91.17
12460	8,776	80	85.22
12,503	8,172	78	79.12
12,590	9,753	84	96.25
12,634	9,149	82	90.26
12,677	8,545	80	84.12
12,720	7,942	78	77.84
12,807	9,522	84	95.38
12,851	8,919	82	89.22
12,894	8,315	80	82.90
12,981	9,895	86	100.61
13,025	9,292	84	94.41
13,068	8,688	82	88.06
13,112	8,084	80	81.56
13,199	9,665	86	99.68
13,242	9,061	84	93.29
13,286	8,457	82	86.76
13,373	10,038	88	105.05
13,379	10,076	88	105.11
13,416	9,434	86	98.63
13,460	8,830	84	92.06
13,503	8,227	82	85.35
13,590	9,807	88	104.05
13,633	9,203	86	97.45
13,677	8,600	84	90.70
13,764	10,180	90	109.56
13,807	9,576	88	102.93
13,851	8,973	86	96.15
13,894	8,369	84	89.22
13,981	9,950	90	108.49

NOTE:

- Other sizes are available, please contact an Armtec representative
- H = 425mm (spacing between periphery holes)
- Span, rise and end area measurements are based on inside dimensions

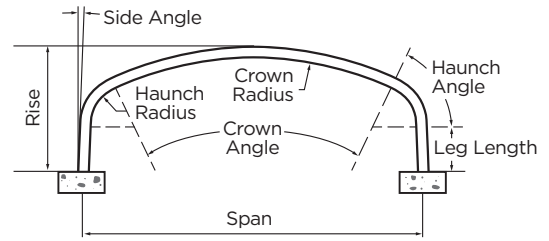

Table 9: Box Culvert BRIDGE-PLATE technical data

Structure	Span	Rise	Total	End Area
Ref.	mm	mm	H	m ²
12-40	4,000	1,220	12	3.94
14-40	4,050	1,400	13	4.71
14-45	4,500	1,400	14	5.29
14-50	5,000	1,400	15	5.85
14-55	5,500	1,400	15	5.78
15-38	3,810	1,500	13	4.81
15-43	4,300	1,500	14	5.44
15-48	4,800	1,500	15	6.04
16-41	4,100	1,600	14	5.55
16-52	5,200	1,600	16	6.84
16-61	6,100	1,600	18	4.85
18-46	4,600	1,800	16	7.16
18-52	5,200	1,800	17	7.93
18-58	5,800	1,800	18	8.62
18-68	6,800	1,800	20	10.00
20-42	4,250	2,000	16	7.31
20-49	4,900	2,000	17	8.21
20-55	5,500	2,000	18	9.00
20-61	6,100	2,000	19	9.56
20-65	6,500	2,000	20	10.56
20-73	7,300	2,000	22	12.16
22-45	4,500	2,200	17	8.30
22-50	5,000	2,200	18	9.25
22-52	5,200	2,200	19	10.08
22-70	7,000	2,200	22	12.79
22-76	7,600	2,200	23	13.61
24-49	4,900	2,400	19	10.22
24-55	5,500	2,400	20	11.31
24-61	6,100	2,400	21	12.33
24-66	6,600	2,400	22	13.27
24-71	7,100	2,400	23	14.23
24-77	7,750	2,400	24	15.17
26-60	6,000	2,600	22	13.55
26-70	7,000	2,600	24	15.73
26-73	7,300	2,600	24	15.73
28-61	6,100	2,800	23	14.79
28-67	6,700	2,800	24	16.11
28-76	7,620	2,800	26	18.37
30-68	6,800	3,000	25	17.56
30-74	7,400	3,000	26	18.87
30-78	7,775	3,000	27	20.03

Structure	Span	Rise	Total	End Area
Ref.	mm	mm	H	m ²
20-80	8,000	2,000	23	12.80
20-90	8,750	2,002	25	14.43
22-80	8,000	2,197	24	14.48
22-90	9,000	2,202	26	16.15
22-100	10,000	2,200	28	17.70
24-85	8,500	2,402	26	17.14
24-95	9,500	2,395	28	18.90
24-110	11,000	2,403	31	21.46
26-85	8,500	2,602	27	18.87
26-100	10,000	2,597	29	20.60
26-115	11,500	2,599	32	23.32
28-80	8,002	2,804	27	19.50
28-100	10,000	2,797	30	22.73
28-110	11,000	2,797	32	24.77
28-120	12,000	2,799	34	26.69
30-80	8,000	2,995	28	21.15
30-90	9,000	2,997	29	22.54
30-100	10,000	3,003	31	24.87
30-110	11,001	3,000	33	27.12
30-120	12,000	3,000	35	29.30
32-90	9,000	3,195	30	24.41
32-100	10,000	3,195	32	26.88
32-110	11,000	3,198	34	29.34
32-120	12,000	3,200	36	31.73
34-100	10,024	3,399	33	28.99
34-110	11,000	3,400	35	31.69
34-120	12,000	3,402	37	34.26
36-110	11,049	3,600	36	33.95
36-120	12,001	3,597	37	35.34
38-115	11,500	3,795	37	36.34
38-125	12,500	3,797	39	39.28

NOTE:

- Other sizes are available, please contact an Armtec representative
- H = 425mm (spacing between periphery holes)
- Span, rise and end area measurements are based on inside dimensions

Typical Specification For BRIDGE-PLATE Structure

1. Scope

1.1 This specification covers BRIDGE-PLATE, commonly referred to as Deep Corrugated Structural Plate (DCSP) and typically used in the construction of field assembled soil-steel structures.

1.2 This is a material specification. The main parts of the specification include approved manufacturers, materials, fabrication, hardware and accessories, and coating.

1.3 The plates shall be manufactured so that, when assembled, they shall form the size and shape of structure as shown on the plans.

1.4 Assembly and backfilling, not covered in this specification, shall follow the manufacturer's recommendations.

2. Manufacturer

2.1 The manufacturer of the Deep Corrugated Structural Plate shall be Armtec, or an equal, approved by the engineer.

2.2 An "approved equal" manufacturer must have written approval from the engineer prior to submitting a bid for the project. A manufacturer requesting approval from the engineer must supply a list of similar projects for review.

3. Materials

3.1 Plates shall be fabricated from a base steel made by the open-hearth, basic-oxygen, or electric furnace process.

3.2 The chemical composition (by heat analysis) of the steel shall be such that it will have a composition with a maximum sulfur content of 0.04% and a maximum combined carbon, manganese, phosphorous, silicon, and sulfur content of 1.86%. The tolerances over the maximum limit (by product analysis) shall be +0.01% and +0.13% respectively.

3.3 The chemical composition shall be such that it does not negatively impact galvanizing of the plates.

3.4 The mechanical properties of the flat plates prior to corrugating shall be such that they will have a minimum yield strength of 275 MPa, a minimum tensile strength of 380 MPa, and a minimum elongation of 25% in 50mm. These properties normally provide a minimum design yield strength of 300 MPa after the plates are corrugated.

3.5 Standard plate thicknesses include 4.3, 5.0, 6.0, 7.0 and 8.0mm.

4. Fabrication

4.1 Deep Corrugated Structural Plate shall be formed from materials specified in the clauses under 3.0 Materials.

4.2 The width of the plates shall be three corrugations wide.

4.3 The depth of the corrugation shall have a nominal dimension of 150mm and shall not be less than 144mm.

4.4 The pitch of the corrugation shall have a nominal dimension of 400mm and shall not be more than 413mm.

4.5 The inside radius of the corrugation shall have a nominal dimension of 81mm and shall not be less than 74mm.

4.6 All plates shall be punched for bolting at both longitudinal and circumferential seams.

4.7 The longitudinal seam shall be of the lap type of connection. The bolt hole arrangement shall consist of three rows of holes spaced at 100mm on centres, with a hole located in the valley and crest of each corrugation. The centreline of the first row of holes shall be nominally 40mm from the end of the plate. All holes are 25mm diameter unless noted. The three holes along each edge of the plate (the circumferential seam location) and two outside crest holes in the middle row of longitudinal seam holes are slotted holes measuring 24mm wide by 29mm long.

4.8 The designation used to describe the circumferential hole spacing is H, which has a value of 425mm. Plate lengths shall be a multiple of the circumferential hole spacing to accommodate circumferential staggering of the longitudinal seam in adjacent rings of plates. The centre line of the row of holes shall be nominally 40mm from the edge of the plate. All circumferential bolt holes are slotted holes measuring 24mm wide by 29mm long.

4.9 The plates shall be accurately curved to suit the shape of the structure cross section. All members of a similar type, thickness and length shall be interchangeable.

5. Hardware & Accessories

5.1 Bolts shall be 3/4 inch [19mm] diameter or 7/8 inch [22mm] diameter ANSI B18.2.1 Heavy Hex Head Bolts to ASTM A449 with a zinc coating to ASTM A153 or B695, Class 55. They shall have the bearing surface shaped to a 25mm radius spherical surface.

5.2 Nuts shall be ANSI B18.2.2 Heavy Hex Nuts to ASTM A563 Grade C with a zinc coating to ASTM A153 or B695, Class 55, and shall be sized to suit the bolts. They shall have the bearing surface shaped to a 25mm radius spherical surface.

5.3 When specified, galvanized metal channels, for the connection of arches to footings, are provided.

5.4 Anchor bolts for head walls, collars and anchorage of arches to footings shall be 3/4 inch (19mm) diameter ANSI B18.2.1 Heavy Hex Head Bolts to ASTM A307 with a zinc coating to ASTM A153 or B695, Class 55.

5.5 Nuts for anchor bolts shall be 3/4 inch (19mm) diameter ANSI B18.2.2 Heavy Hex Nuts to ASTM A563 Grade A with a zinc coating to ASTM A153 or B695, Class 55, and shall be sized to suit the anchor bolts.

6. Coating

6.1 The plates shall be galvanized after corrugating, punching and curving.

6.2 Zinc shall conform to ASTM B6 and shall be at least equal to "Prime Western" grade.

6.3 The zinc coating mass (total on both sides) shall not be less than 915g/m² when tested by the triple spot test, or 825g/m² when tested by the single spot test.

6.4 The test for coating mass acceptance shall be by non-destructive magnetic thickness test methods in accordance with ASTM E376. In cases of dispute, the basis for rejection shall be a chemical weigh-strip-weight test as specified in CAN/CSA-G164.

6.5 The 915g/m² zinc mass is equivalent to a 64µm zinc thickness measured on one side by the magnetic test method. The 825g/m² zinc mass is equivalent to a 58µm zinc thickness.

6.6 The zinc coating shall be free from injurious defects such as blisters, excessive flux, storage stains, foreign inclusions, and uncoated areas more than 3mm wide.

6.7 Uncoated areas that are more than 3mm and up to 50mm wide shall be repaired by thorough cleaning followed by the application of a zinc-rich coating. The coating shall conform to CAN/CGSB-1.181 and shall be applied to a dry thickness of at least 50µm.

NOTE:

Polymer coating can be specified as per the Strata-CAT product guide. **Ask an Armtec representative for more information.**

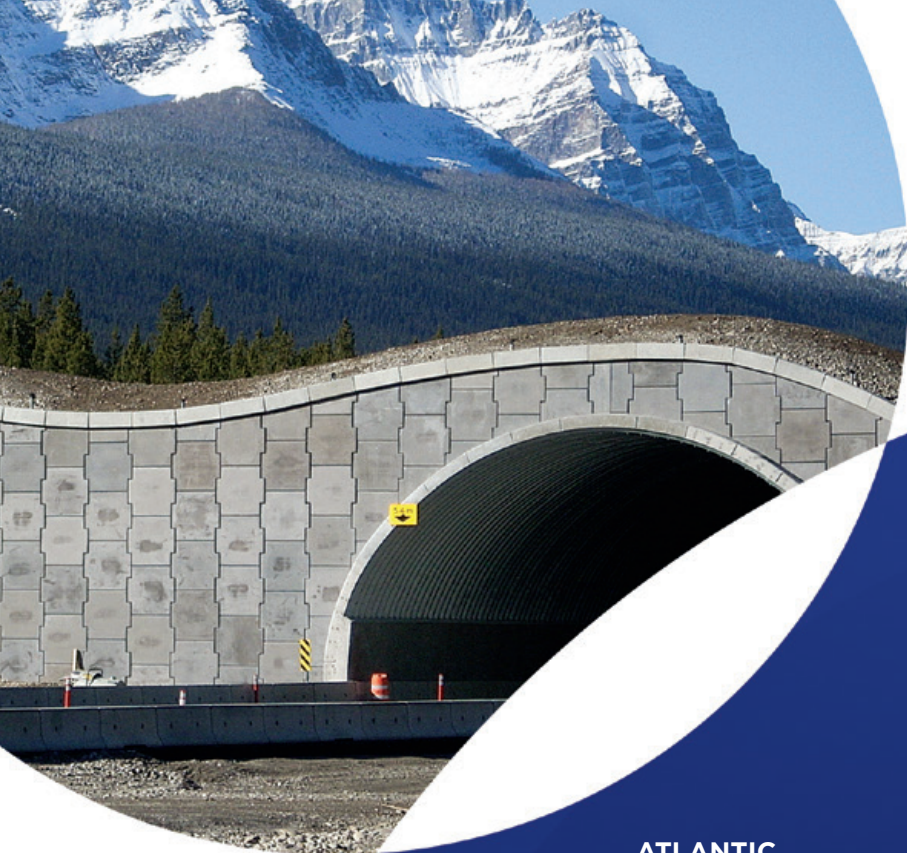

Armtec is environmentally conscious
by supporting limited paper usage.

ATLANTIC

Shediac, NB
Sackville, NB
Truro, NS
Bishop's Falls, NL
St. John's, NL

CENTRAL

Cambridge, ON
Comber, ON
Forest, ON
Guelph, ON
Orangeville, ON
Peterborough, ON
Sudbury, ON
Thunder Bay, ON
Walkerton, ON
Woodstock, ON
St-Augustin, QC
St-Clet, QC

PRAIRIES

Calgary, AB
Edmonton, AB
Grande Prairie, AB
Ponoka, AB
Redwater, AB
Winnipeg, MB
Regina, SK
Saskatoon, SK

WESTERN

Dawson Creek, BC
Genelle, BC
Langley, BC
Nanaimo, BC
Prince George, BC



Platinum member

Find out how **BRIDGE-PLATE** can be used on your next project.
Call **1-800-565-1152** or visit **armtec.com**