



INSTALLATION MANUAL FOR

- Sluice Gates
- Fabricated Gates
- Drainage Gates
- Specialty Gates

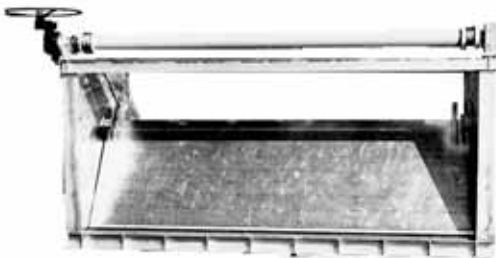

TABLE OF CONTENTS

HEAVY DUTY SLUICE GATE INSTALLATION INSTRUCTIONS..... 2-8

MEDIUM & LIGHT DUTY SLUICE GATE INSTALLATION INSTRUCTIONS9-14

FABRICATED SLIDE GATE INSTALLATION INSTRUCTIONS 15-22

DRAINAGE (FLAP)(TIDE) GATE INSTALLATION INSTRUCTIONS23-27

SPECIALTY PRODUCTS INSTALLATION INSTRUCTIONS28-31

NOTES 32

HEAVY DUTY SLUICE GATE INSTALLATION INSTRUCTIONS

FOREWORD

The purpose of this manual is to provide the contractor with all pertinent information for the proper installation of our Series 4000/5000/7000 and P-32 sluice gates. Although every care is taken in our factory to insure top quality equipment, we cannot be responsible for damage caused by negligence after shipping. Therefore, described herein are Waterman's recommended methods of handling, storage, installation, adjustment and initial operation for standard situations, to be used in conjunction with the approved installation drawings provided by Waterman Industries, Inc. If proper care and accuracy are exercised in the field when installing our gates, they will operate as designed at maximum efficiency.

RECEIVING, HANDLING AND STORAGE

✓ **Check count** on all parts when you receive a shipment, noting any shortages immediately. We cannot be responsible for shortages reported after any lengthy delay. Special care should be taken in accounting for and safely storing all bolts, nuts, and small items which are often misplaced at jobsites. (Waterman double counts these parts to assure accuracy.)

All Waterman gates and appurtenances are precision machinery and should be handled accordingly. While all parts are of a rugged design, it is nevertheless possible to warp machined surfaces, stems, etc., through improper storage and handling. To avoid all problems of this nature we recommend the following:

1. Lift gates through stem hole in top of lift nut box on cover only when shipping stops are in place, taking particular care of wedges and seats.
2. Support full length of stems at all times, being sure not to damage threads.
3. Store equipment on an even, clean, dry surface to prevent distortion.
4. Cover all equipment to protect machined surfaces.
5. **Do not** stack equipment without protection.
6. Handle lifts as you would any precision machinery.

CAUTION: This gate has been adjusted at the factory. **DO NOT DISASSEMBLE.** Refer to operation manual before attempting to adjust. **DO NOT** paint bronze, stainless steel or machined surfaces as damage may result.

PROCEDURE FOR INSTALLING A STANDARD FLANGEBACK OR EXTENDED FLANGEBACK GATE ON A CONCRETE HEADWALL

1. Secure all anchor bolts in proper position in the forms, checking carefully to see that size, projection, perpendicular and horizontal alignments conform to requirements shown on our illustration. Extreme care must be exercised in this initial procedure in that bolts which are improperly set will cause gate warpage and therefore excess leakage between the seating surfaces. **Do Not Force Gate Onto Misaligned Bolts.**

Figure 1

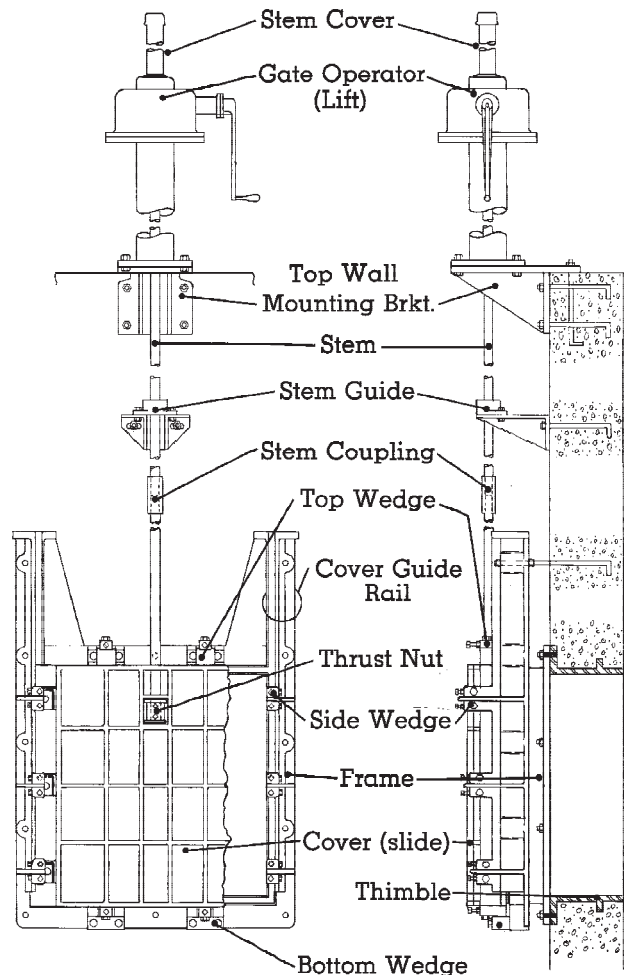

2. Each bolt has been provided with two nuts to facilitate proper mounting of the gate. In setting the forms, provide a recess around the perimeter of the gate, as shown in Figure 2. This is recommended only if access from the back of the gate is possible, allowing easy adjustment of the back nut. Otherwise sufficient grout space must be left for adjustment of the back nut as shown in Figure 3. **Note:** In this case, the projection specified on our installation drawing must be increased by the amount of the grout space allowed.
3. After concrete has been poured and the forms have been stripped, place one nut on each anchor bolt and run down against headwall. **Do Not Disassemble Gate For Installation.** Place the completely assembled gate into position carefully guiding it onto the anchor bolts. (Again we must reiterate, **Do Not Force Gate Onto Misaligned Bolts.** See 1, page 2.) Place the second nut on each bolt and bring both front and back nuts into finger-tight contact with gate frame, aligning it as necessary. At this point, check clearance between seating surfaces (from back of gate if possible) with .004" feeler gauge. If gate is seating properly, the gauge will not be admitted at any point. In the event that the gate is not seating properly, check to see if gate has been warped during installation. If so, adjust nuts on anchor bolts to bring frame into flatness. Otherwise a single adjustment of the wedges is all that is necessary. (see section on wedge adjustments.)
4. After gate is found to be seating properly, carefully drypack or grout in the gate between frame and headwall using a non-shrink material. Check for voids after it has set and fill in as necessary.
5. Tighten all nuts on anchor bolts uniformly, taking care not to warp gate to conform to uneven surface. Gate is now ready for initial operation. **Note:** In those locations where extended flangeback gates are used on headwalls without sufficient side or bottom clearance for nut adjustments, anchor bolts can be brought through the gate frame to the front face. Special anchors and frame drilling must be ordered.

Figure 2

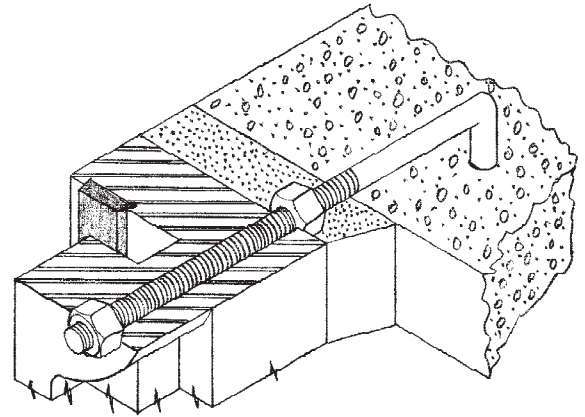
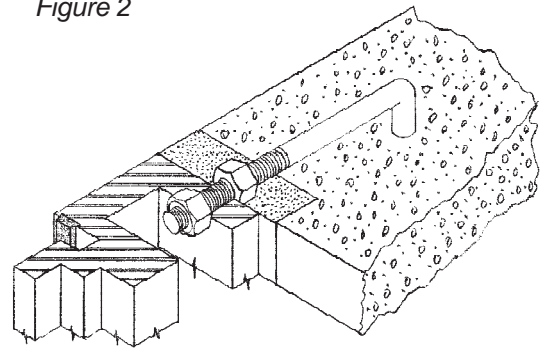

Figure 3

PROCEDURE FOR INSTALLING A STANDARD FLANGEBACK OR EXTENDED FLANGEBACK GATE ON A WALL THIMBLE OR PIPE FLANGE

1. Place the thimble in correct position in the forms and secure in place. The top (marked on the flange face) should be aligned with a plumb. Thimble should be flush or projecting slightly from the head wall face.
2. Use timbers or other bracing on the inside of the opening to support the thimble and prevent warpage during the pour. This is especially important on larger thimbles or when the concrete cover will be especially high.
3. Plug the tapped holes in the thimble with the studs provided or other removable plugs that will prevent concrete from entering the tapped holes.
4. Secure anchor bolts for guide rail extensions (or provide block out) in the proper position as given on our installation drawing, (your submittal drawing provided by the manufacturer). Check projection and perpendicular alignment of these anchors.
5. Pour concrete, using care not to tilt or move thimble from its original position in the forms.
6. Let concrete set, then remove forms and bracing. Thoroughly clean the front machined face of the thimble and place cleaned studs into tapped holes provided.
7. Clean the back of the gate frame or flange thoroughly. Apply a thin coat of mastic (such as butyl rubber compound or black asphaltic compound), on the front face of the thimble.
8. Mount the completely assembled gate on the thimble. Place nuts on studs and tighten uniformly until a metal to metal contact is made, removing excess mastic.
9. Check clearance between seating surfaces with .004" feeler gauge. In the event that the gate is not seating properly, make wedge adjustments. (Another cause of improper seating is warpage of gate frame due to mounting on thimble which has been warped during the pouring of concrete. If steps one through five are strictly adhered to this will be avoided and the mounting of the gate will be a simple procedure.) Gate is now ready for initial operation.

PROCEDURE FOR INSTALLING STEMS AND STEM GUIDES

1. After the gate has been mounted and shipping stops have been removed, lower short-threaded end of stem through holes in upper ribs of cover.
2. Thread stem into thrust nut in nut pocket on cover until flush with bottom of nut.
3. Tighten set screws on nut into indents in stem.
4. Mount stem guides in order from bottom up as stem is installed. Do not tighten stem guide assembly bolts.
5. Install stem couplings as required, being sure to tighten all set screws or drive in pins.
6. Take care not to bend stems or damage threads during installation.

PROCEDURE FOR INSTALLING LIFTS

Manually Operated Lifts

1. After assembling stem as described earlier, lower the lift over the upper threaded portion of stem, carefully engaging threads of lift nut and stem.
2. Bring base of lift over anchor bolts to about 1" from floor and adjust lower nut until proper vertical alignment is achieved. (Not necessary with wall bracket mounting.)
3. Tighten top nuts on anchor bolts and grout in place.
4. Once the lift is properly installed, apply tension to the stem with the lift and align the stem guides. Tighten stem guide assembly bolts.

Hydraulic Cylinder Lifts

1. Lower cylinder onto mounting device and align and secure as described above.
2. Couple the piston rod to the stem.
3. Attach pertinent hardware to cylinder.
4. Put tension on stem with lift and set stem guides.
5. With the piston down against the lower head of the cylinder, and the gate in the fully closed position, rotate the stem in the thrust nut until the nut fits snugly against the bottom of the nut pocket.
6. Tighten all set screws.

Electric Lifts

1. Install in the same manner as the manual lifts.
2. After alignment, manually open gate a few inches before initial electric operation. This is a safety measure to protect the gate in case lift has been improperly connected.

INSTALLATION ON TOP WALL MOUNTING BRACKET

1. Mount top wall mounting bracket on anchor bolts, and secure with nuts. Top surface must be aligned perpendicular * with stem, and stem must pass approximately through center of stem slot.
*If wall face or top is unduly rough or badly out of plumb, wall may need to be grout-faced to provide proper mounting surface for bracket.
2. After assembling stem *, loosen the lift over the upper threaded portion of stem carefully engaging threads of lift nut and stem.
* If a limit nut is to be used to stop upward gate travel, it must be installed on the stem prior to installing the lift.
3. Bring base over top of bracket and mount with four bolts and nuts. Adjust floorstand until proper alignment is achieved. Tighten bolts.
4. Once the lift is properly installed, apply tension to the stem with the lift and align the stem guides. Tighten stem guide assembly bolts.

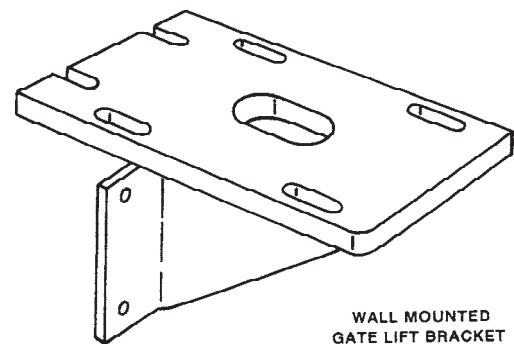

Figure 4

SETTING POSITION INDICATORS

1. When installing a manually operated lift with position indicator, remove the indicator prior to mounting.
2. After the lift has been properly installed, lower the gate until the bottom seating surface of the cover just meets the bottom seating surface of the frame. This is the point of zero opening.
3. Set the indicator to zero and replace it on the lift, making sure that as the gears are engaged the indicator does not move from zero.
4. Note that in the full wedging position, the indicator will read less than zero.
5. See manufacturer's instructions for the setting of electric lifts.

PROCEDURE FOR SETTING CLEAR PLASTIC STEM COVER INDICATORS

1. Indicator strips are attached after the lift and stem cover have been installed and the gate has been adjusted for proper seating.
2. Be certain that the stem cover is clean and dry, inside and out. Use mild detergent or commercial cleaners specifically made for plastic.
3. Observe through the stem cover where the top of the stem is positioned when the gate is fully closed. Make a small mark on the outside of the stem cover at this point. This is your "zero" reference.
4. The mylar strip is graduated in increments with "0" at the bottom. Peel off the paper backing (the mylar strip is self-adhesive) then starting at the "zero" reference attach the mylar strip, taking care to avoid bubbles and wrinkles.
5. Cut off any excess strip that extends past the pipe cap.

CLEANING AND ADJUSTING

1. After installation of the stem, stem guides, and lifting mechanism, move slide (cover) to fully open position. **Be sure shipping stops have been removed.**
2. Clear all dirt, paint, etc. off of seating and wedging surfaces, and clean loose concrete and grout from top of gate.
3. Grease seating and wedging surfaces with water resistant grease.
4. Close gate completely and check for proper wedge adjustment. **Note:** All wedges are factory adjusted before shipment, but may have loosened during shipping, handling and installation. Use a .004" feeler gauge to check for excess clearance between seating faces. (Best results can be obtained by checking seat faces from back side of gate when installation permits.)

PROCEDURE FOR ADJUSTING SIDE WEDGES ON SERIES 4000 UP TO 14"

1. Loosen wedge locking nut on guiderail (A1).
2. Loosen adjusting screw lock nut (A2).
3. Tighten adjusting screw (A3) until proper seating is attained.
4. Tighten wedge locking nut (A1).
5. Tighten adjusting screw lockout (A2).

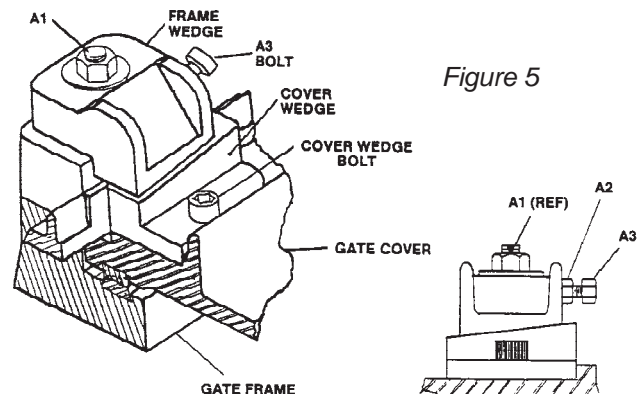

Figure 5

PROCEDURE FOR ADJUSTING SIDE WEDGES ON SERIES 4000 15" AND LARGER

Side wedges (adjustable portion of wedge on slide)

1. Open gate slightly.
2. Loosen locking nut (B1) [$\frac{1}{2}$ " nc hex nut].
3. Loosen adjusting screw lock nut (B2) [$\frac{3}{8}$ " nc hex nut].
4. Move wedge down into desired position by turning adjusting screw (B3) [$\frac{3}{8}$ " nc x $1\frac{3}{4}$ " lg hex hd bolt].
5. Tighten locking bolts (B1).
6. Tighten adjusting screw lock nut (B2).
7. Close gate and check with .004" feeler gauge.
8. Repeat procedure as necessary until desired closing is attained.
9. Check to see that gate cover will repeat final closed position. If gate cover will not repeat - readjust.

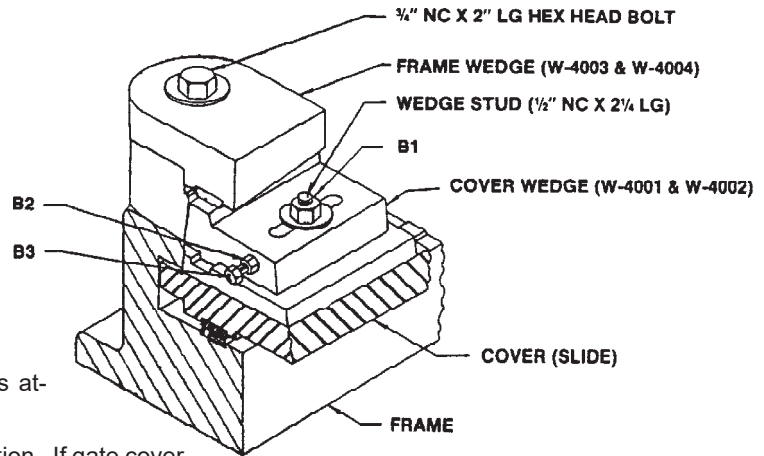

Figure 6

PROCEDURE FOR ADJUSTING TYPE A SIDE WEDGES ON SERIES 5000/7000 SLUICE GATES

Type "A" Standard Side Wedges
(Adjustable portion of wedge on guide rail)

1. Loosen wedge locking bolts on guide rail (A1) [$\frac{1}{2}$ " nc x 2 lg hex hd bolt].
2. Loosen adjusting screw lock nuts (A2) [$\frac{3}{8}$ " nc hex nut].
3. Tighten both adjusting screws until proper seating is attained (A3) [$\frac{3}{8}$ " nc x $2\frac{1}{2}$ " lg sq hd set screw].
4. Tighten locking bolts (A1).
5. Tighten adjusting screw lock nuts (A2).
6. Upon final adjustment of wedges check to see that gate cover will repeat its final closing travel. If wedges are set too tight gate position on full closure cannot be repeated. If gate will not repeat - readjust wedges.

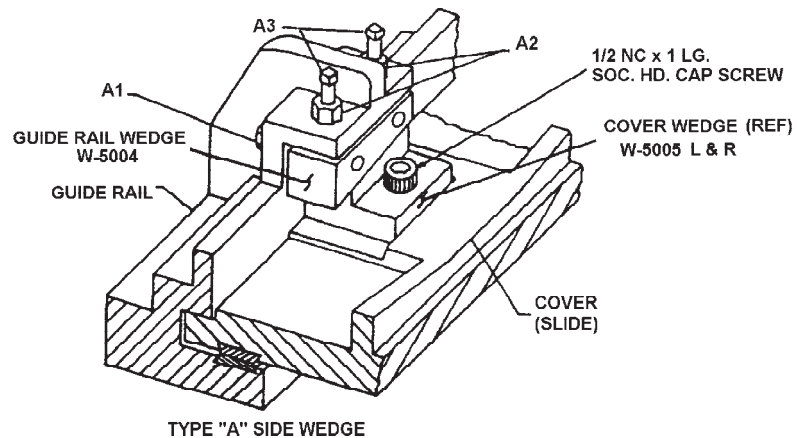

Figure 7

PROCEDURE FOR ADJUSTING TYPE B SIDE WEDGES ON SERIES 5000/7000 SLUICE GATES

Type "B" Side Wedges
(Adjustable portion of wedge on slide)

1. Open gate slightly.
2. Loosen locking bolts (B1) [$\frac{5}{8}$ " nc x $1\frac{1}{2}$ " lg. sq. hd. set screw].
3. Loosen adjusting screw lock nut (B2) [$\frac{3}{8}$ " nc hex].
4. Move wedge down into desired position by turning adjusting screw (B3) [$\frac{3}{8}$ " nc x $2\frac{1}{2}$ " lg sq. hd. set screw].
5. Tighten locking bolts (B1).
6. Tighten adjusting screw lock nut (B2).
7. Close gate and check with .004" feeler gauge.
8. Repeat procedure as necessary until desired closing is attained.
9. Check to see that gate cover will repeat final closed position. If gate cover will not repeat - readjust.

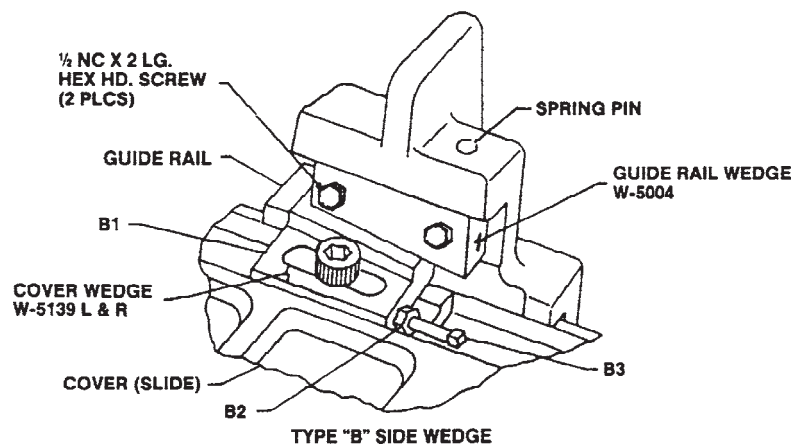

Figure 8

PROCEDURE FOR ADJUSTING TYPE B-1 SIDE WEDGES ON SERIES 5000 SLUICE GATES

1. Open gate slightly.
2. Loosen wedge lock nut (C1) $\frac{5}{8}$ " hex nut.
3. Loosen adjusting screw lock nut.
4. Move wedge up or down as desired (up to decrease wedge action, down to increase wedge action) turning adjusting screw against cover wedge stud.
5. Tighten wedge locknut (C1).
6. Tighten adjusting screw locknut.
7. Close gate and check seat clearance with .004" feeler gauge.
8. Repeat procedure as necessary until desired closing is attained.

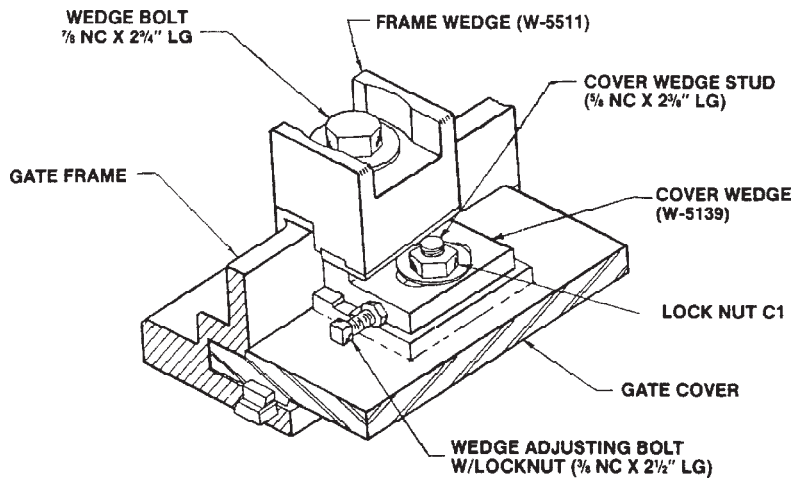

Figure 9

PROCEDURE FOR ADJUSTING SIDE WEDGES ON P-32 SLUICE GATES

1. Loosen wedge locking nut on guiderail (A1).
2. Loosen adjusting screw locknut (A2).
3. Tighten adjusting screw (A3) until proper seating is attained.
4. Tighten wedge locking nut (A1).
5. Tighten adjusting screw locknut (A2).

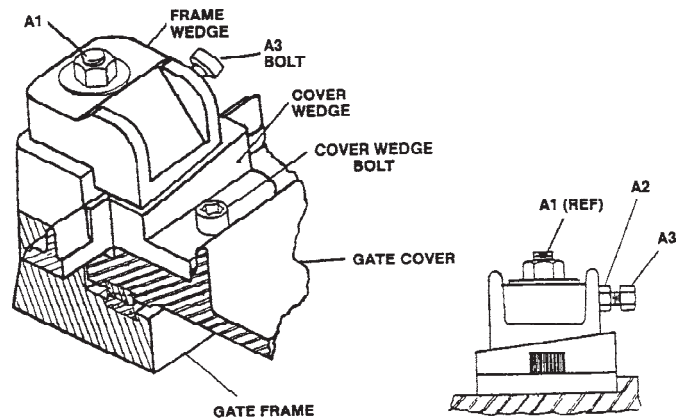

Figure 10

PROCEDURE FOR ADJUSTING TOP AND BOTTOM WEDGES ON SERIES 4000 SLUICE GATES

1. Loosen locking bolt slightly (T1) (L1).
2. Loosen adjusting screw lock nut (T2) (L2) [$\frac{3}{8}$ " nc hex].
3. Tighten adjusting screw until proper seating is attained. (T3) (L3) [$\frac{3}{8}$ " nc x $1\frac{3}{4}$ " lg hex hd bolt]
4. Tighten locking bolt (T1) (L1).
5. Tighten adjusting screw lock nut (T2) (L2).

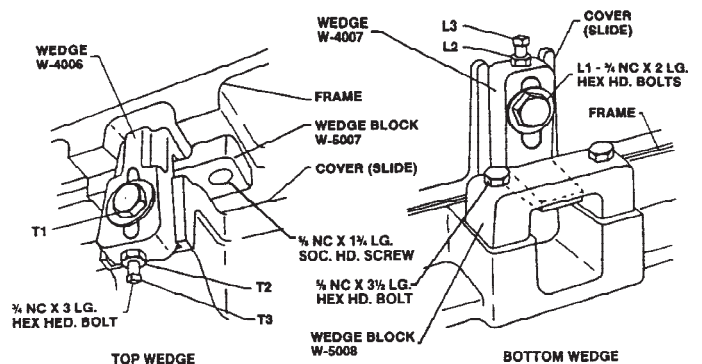

Figure 11

PROCEDURE FOR ADJUSTING TOP AND BOTTOM WEDGES ON SERIES 5000/7000 SLUICE GATES

1. Loosen locking bolt slightly (T1) (L1) [$\frac{3}{4}$ " nc x 3" lg hex hd bolt].
2. Loosen adjusting screw lock nut (T2) (L2) [$\frac{1}{2}$ " nc hex].
3. Tighten adjusting screw until proper seating is attained (T3) (L3) [$\frac{1}{2}$ " nc x 2" lg sq. hd. set screw].
4. Tighten locking bolt (T1) (L1).
5. Tighten adjusting screw lock nut (T2) (L2).

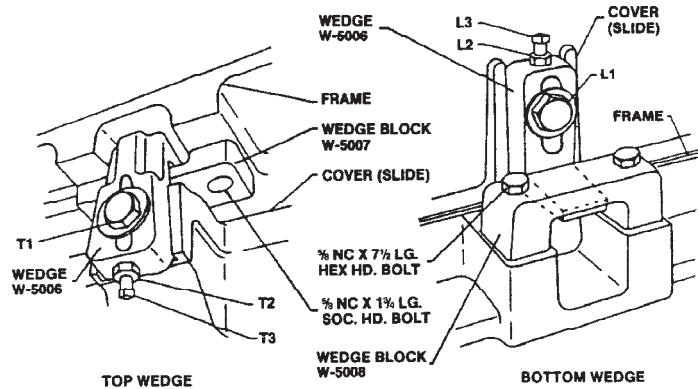

Figure 12

WEDGE ADJUSTMENT ON FLUSHBOTTOM HEAVY DUTY SLUICE GATES

1. If wedge adjustment is necessary on a flushbottom sluice gate, a slightly different procedure is required.
 - a. Loosen all wedges as described previously.
 - b. Loosen slide until it compresses the resilient seal enough for proper seating.
 - c. Adjust all wedges as described previously.

WEDGE ADJUSTMENT SEQUENCE

NOTE: All wedges should seat with equal pressure. If all wedges should need adjusting, the sequence shown is suggested:

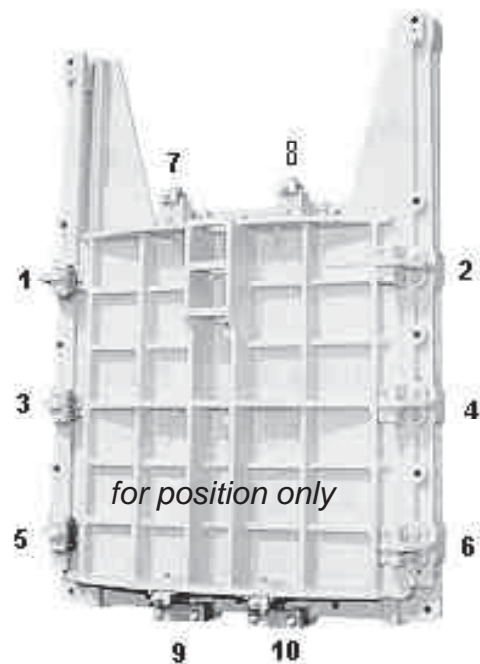

Figure 13

LUBRICATION RECOMMENDATIONS

1. Grease machined iron surfaces and bronze seats and wedging surfaces with NO-OX-ID, manufactured by Dearborn Chemical Division, W.R. Grace and Co. or equal.
2. Grease stainless steel seats and wedging surfaces with Never-Seez, manufactured by Never-Seez Corp. or equal. For best results mix Never-Seez with an equal portion of ten-weight oil.
3. Lubricate Waterman Gate Lifts with Lubriplate, Type 630-AA, manufactured by Fisk Brothers Refining Co. or equal, at three month intervals. A one gallon can is a one to two year supply for three lifts.

Note: Use caution when filling pinion shafts on Type 3 lifts. DO NOT OVER FILL.

MEDIUM & LIGHT DUTY SLUICE GATE INSTALLATION INSTRUCTIONS

FOREWORD

The purpose of this manual is to provide the contractor with all pertinent information for the proper installation of our light and medium duty sluice and slide gates. Although every care is taken in our factory to insure top quality equipment, we cannot be responsible for damage caused by negligence after shipping. Therefore, described herein are Waterman's recommended methods of installation, adjustment and initial operation for standard situations, to be used in conjunction with the approved installation drawings (when applicable) provided by Waterman Industries, Inc. If proper care and accuracy are exercised in the field when installing our gates, they will operate as designed at maximum efficiency.

APPLICATION

This manual covers the installation of Waterman Gate Models C-10, CL-10, CM-10, C-20, P-30, and Series 3000. All "C" series gates are completely self-contained, thus the sections covering stem, stem guide and lift installations do not necessarily apply. All Waterman Sluice and Slide Gates listed here are installed in the same basic manner for standard applications. Special applications for particular gates are covered individually.

RECEIVING, HANDLING AND STORAGE

✓ **Check count** on all parts when you receive a shipment, noting any shortages immediately. We cannot be responsible for shortages reported after any lengthy delay. Special care should be taken in accounting for and safely storing all bolts, nuts, and small items which often are misplaced at jobsites. (Waterman double counts these parts to assure accuracy.)

All Waterman gates and appurtenances are precision machinery and should be handled accordingly. While all parts are of a rugged design, it is nevertheless possible to warp machined surfaces, stems, etc., through improper storage and handling. To avoid all problems of this nature we recommend the following:

1. Lift gates through stem hole in top of lift nut box on cover only when shipping stops are in place, taking particular care of wedges and seats (Series 3000).
- 1b. All other models are usually shipped as self-contained and should be installed as complete assemblies. Lifting should be done carefully to avoid damage to the yoke or headrail.
2. Support full length of stems at all times, being sure not to damage threads.
3. Store equipment on an even, clean, dry surface to prevent distortion.
4. Cover all equipment to protect machined surfaces.
5. **Do not** stack equipment without protection.
6. Handle lifts as you would any precision machinery.

PROCEDURE FOR INSTALLING A FLATBACK OR FLANGEBACK GATE ON A CONCRETE HEADWALL WITH ANCHOR BOLTS

1. Secure all anchor bolts in proper position in the forms, checking carefully to see that size, projection, perpendicular and horizontal alignments conform to requirements shown on our installation drawing. **Extreme care** must be exercised in this initial procedure in that bolts which are improperly set will cause gate warpage and therefore excess leakage between the seating surfaces. **DO NOT FORCE GATE ONTO MIS-ALIGNED BOLTS.**
2. Each bolt is normally provided with two nuts to facilitate proper mounting of the gate. In setting the forms, provide a recess around the perimeter of the gate, as shown in Figure 14. This is recommended only if access from the back of the gate is possible, allowing easy adjustment of the

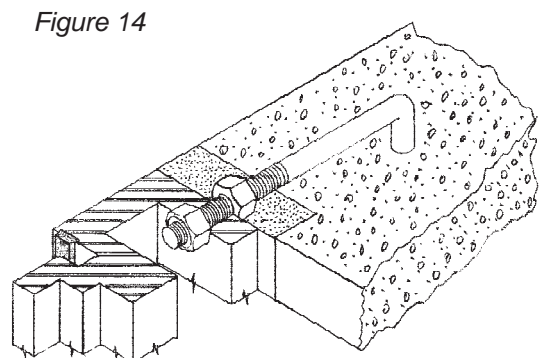

back nut. Otherwise sufficient grout space must be left for adjustment of the back nut as shown in Figure 15. NOTE: In this case, the projection specified on our installation drawing must be **increased** by the amount of the grout space allowed.

3. After concrete has been poured and the forms have been stripped, place one nut on each anchor bolt and run down against headwall. **DO NOT DISASSEMBLE GATE FOR INSTALLATION.** Place the **completely assembled** and closed gate into position carefully guiding it onto the anchor bolts. (Again we must reiterate, **DO NOT FORCE GATE ONTO MISALIGNED BOLTS.** See 1, pg. 9.) Place the second unit on each bolt and bring both front and back nuts into finger-tight contact with gate frame, aligning it as necessary. At this point, check clearance between seating surfaces (from back of gate if possible) with .004" feeler gauge. If gate is seating properly, the gauge will not be admitted at any point. In the event that the gate is not seating properly, check to see if gate has been warped during installation. If so, adjust nuts on anchor bolts to bring frame into flatness. Otherwise a single adjustment of the wedges is all that is necessary. (See Section on wedge adjustments.)

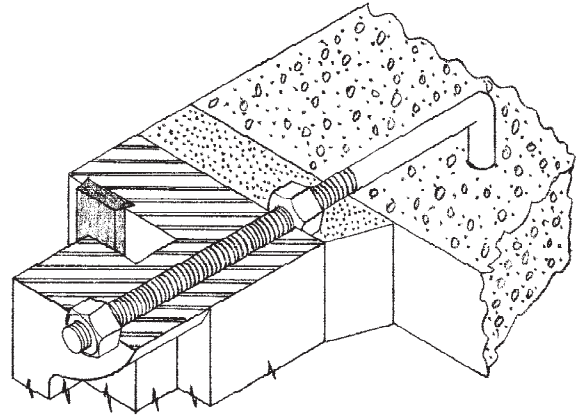

Figure 15

4. After gate is found to be seating properly, carefully drypack or grout between gate frame ring and headwall using a non-shrink material. Check for voids after it has set and fill in as necessary.
5. Lightly tighten all nuts on anchor bolts uniformly, taking care not to warp gate to conform to uneven surface. Gate is now ready for initial operation.

PROCEDURE FOR INSTALLING A FLATBACK OR FLANGEBACK GATE ON A WALL THIMBLE OR PIPE FLANGE

1. Place the thimble in correct position in the forms and secure in place. The top and bottom center-line is marked on the flange face and should be aligned with a plumb. Thimble should be flush or projecting slightly from the headwall face.
2. Use timbers or other bracing on the inside of the opening to support the thimble and prevent warpage during the pour. This is especially important on larger thimbles or when the concrete cover will be especially high.
3. Plug the tapped holes in the thimble with the studs provided or other removable plugs that will prevent concrete from entering the tapped holes.
4. Secure anchor bolts for guide rail extensions (or provide block out) in the proper position as given on our installation drawing, (your certified submittal drawing provided by the manufacturer). Check projection and perpendicular alignment of these anchors.
5. Pour concrete, using care not to tilt or move thimble from its original position in the forms.
6. Let concrete set, then remove forms and bracing. Thoroughly clean the front machined face of the thimble and place cleaned studs into tapped holes provided.
7. Clean the back of the gate frame or flange thoroughly. Apply a thin coat of mastic *such as butyl rubber compound or black asphaltic compound) on the front face of the thimble.
8. Mount the **completely assembled** gate on the thimble. Place nuts on studs and tighten uniformly until a metal to metal contact is made, removing excess mastic.
9. Check clearance between seating surfaces with .004" feeler gauge. In the event that the gate is not seating properly, make wedge adjustments. (Another cause of improper seating is warpage of gate frame due to mounting on a thimble which has been warped during the pouring of the concrete. If steps on through five are strictly adhered to this will be avoided and the mounting of the gate will be a simple procedure.) Gate is now ready for initial operation.

PROCEDURE FOR INSTALLING STEM, STEM EXTENSION, AND STEM GUIDES

1. After the gate has been mounted and shipping stops have been removed, lower end of stem through holes in upper ribs of cover (Series 3000).
2. Thread stem into thrust nut in nut pocket on cover until flush with bottom of nut (Series 3000).
3. Tighten set screws on nut into indents in stem (Series 3000).
4. Mount stem guides in order from bottom up as stem is installed. Do not tighten stem guide assembly bolts.
5. Install stem couplings as required, being sure to tighten all set screws or drive in pins.

6. Take care not to bend stems or damage threads during installation.

NOTE: Models C-10, C-20, and P-30 stems and lifts are contained gate assembly, unless an extension stem is used, in which case stem guides and separate lifts may be used.

PROCEDURE FOR INSTALLING LIFTS

Manually Operated Lifts

1. After assembling stem as described above, lower the lift over the upper threaded portion of stem, carefully engaging threads of lift nut and stem.
2. Bring base of lift over anchor bolts to about 1" from floor and adjust lower nut until proper vertical alignment is achieved. (Not necessary with wall bracket mounting.)
3. Tighten top nuts on anchors and grout in place.
4. Once the list is properly installed, apply tension to the stem with the lift and align the stem guides. Tighten stem guide assembly bolts.

Hydraulic Cylinder Lifts

1. Lower cylinder onto mounting device and align and secure as described above.
2. Couple the piston rod to the stem.
3. Attach pertinent hardware to cylinder.
4. Put tension on stem with lift and set stem guides.
5. With the piston down against the lower head of the cylinder and the gate in the fully closed position, rotate the stem in the thrust nut until the nut is snugly against the bottom of the nut pocket.
6. Tighten all set screws.

Electric Lifts

1. Install in the same manner as the manual lifts.
2. After alignment **manually** open gate a few inches before initial electric operation.

This is a safety measure to protect the gate in case lift has been improperly connected.

SETTING POSITION INDICATORS ON MANUAL LIFTS

1. When installing a manually operated lift with position indicator, remove the indicator prior to mounting.
2. After the lift has been properly installed (See Section on Manually Operated Lifts) lower the gate until the bottom seating surface of the cover just meets the bottom seating surface of the frame. This is the point of zero opening.
3. Set the indicator to zero and replace it one the lift, making sure that as the gears are engaged the indicator does not move from zero. Note that in the full wedging position, the indicator will read less than zero. (See manufacturer's instructions for the setting of electric lifts.)

PROCEDURE FOR SETTING CLEAR PLASTIC STEM COVER INDICATORS

1. Indicator strips are attached after the lift and stem cover have been installed and the gate has been adjusted for proper seating.
2. Be certain that the stem cover is clean and dry, inside and out. Use mild detergent or commercial cleaners specifically made for plastic.
3. Observe through the stem cover where the top of the stem is positioned when the gate is fully closed. Make a small mark on the outside of the stem cover at this point. This is your "Zero" reference.
4. The mylar strip is graduated in increments with "0" at the bottom. Peel off the paper backing (the mylar strip is self-adhesive) then starting at the "zero" reference attach the mylar strip, taking care to avoid bubbles and wrinkles.
5. Cut off any excess strip that extends past the pipe cap.

CLEANING AND CHECKING CLEARANCES

1. After installation of the stem, stem guides, and lifting mechanism and shipping stops have been removed, move slide (cover) to fully open position.
2. Clear all dirt, paint, etc. off of seating and wedging surfaces.

3. Grease seating and wedging surfaces with water resistant grease. (See lubrication section.)
4. Close gate completely and check for proper wedge adjustment. Note: All wedges are factory adjusted before shipment, but may have loosened during shipping, handling and installation. Use a .004" feeler gauge to check for excess clearance between seating faces. (Best results can be obtained by checking seat faces from back side of gate when installation permits.)

PROCEDURE FOR ADJUSTING WEDGES ON SERIES 3000

Side Wedges

1. Loosen nuts on locking bolts.
2. Loosen adjusting screw lock nut.
3. Rotate adjusting screw until proper seating is attained.
4. Tighten nuts on locking bolts.
5. Tighten adjusting screw lock nut.

PROCEDURE FOR ADJUSTING SLUICE GATES WITH FLUSHBOTTOM SEAL

1. If wedge adjustment is necessary on a flushbottom sluice gate, a slightly different procedure is required:
 - a. Loosen all wedges as described above.
 - b. Lower slide until it compresses the resilient seal enough for proper seating.
 - c. Adjust all wedges as described above.

SIDE WEDGE DETAIL (TYPICAL)

- (1) Frame
- (2) Slide with cast-in wedge
- (3) Guide Rail
- (4) Wedge Spacer
- (5) Adjustable Wedge Blocks
- (6) Adjusting Screw and Lock Nut
- (7) Wedge Bolts
- (8) Seat Facings

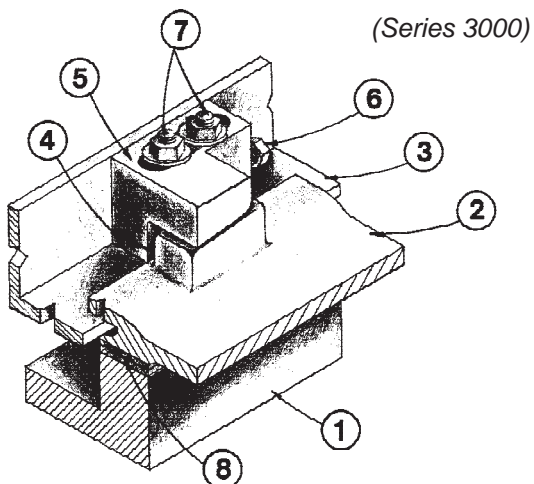

Figure 16

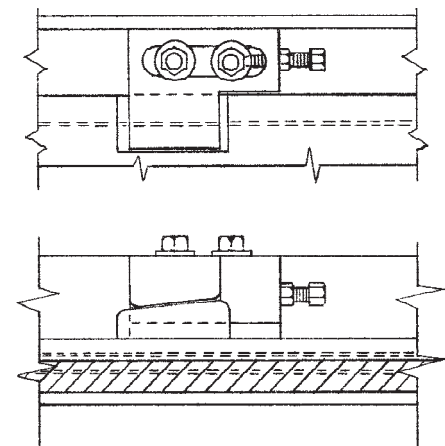

Figure 17

MODELS C-10 AND C-20

1. Loosen nuts on wedge locking bolts.
2. Lightly tap wedges into desired position.
3. Tighten nuts on locking bolts.
4. Check for proper seating and repeat procedure if necessary.

SPECIAL MOUNTINGS for Waterman C-10, C-20, CL-10 and CM-10 Canal Gates

PROCEDURE FOR INSTALLING "sb" SPIGOTBACK GATE ON ANNULAR OR SPIRAL CORRUGATED METAL PIPE

1. Fit spigotback over end of pipe.
2. Using holes in spigot, as a template, drill pipe with 13/32" or 7/16" drill bit.
3. Secure gate to pipe with galvanized steel or brass rivets or bolts.

DO NOT FORCE BOLTS OR RIVETS

4. Apply a sealant (hot tar or other mastic) to the joint between gate and pipe.
5. Brace inside of pipe. DEFLECTION OR DISTORTION OF THE ATTACHED PIPE SECTION MAY CAUSE WARPAGE OF GATE SEAT AND LEAKAGE. This is particularly true of large gates.
6. Place couples gate and pipe in form or ditch and backfill or pour as required, making sure that gate frame is vertical in two planes.
7. Remove bracing and clean gate seats and operating joints. Check to see that seats make proper contact around full periphery of gate. (Use .004" feeler gauge.) Gate is now ready for initial operation.

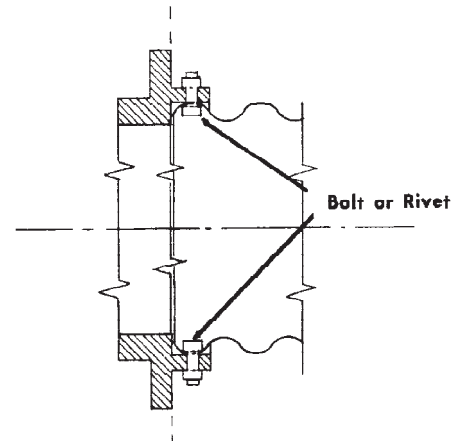

"sb" Spigotback for annular or spiral corrugated pipe.
Figure 18

ATTACHING GATE TO CONCRETE PIPE WITH A TAPER SETTING COLLAR

The light gauge galvanized taper setting collar is used as a "form" for placing grout and as a temporary means of locating a gate in the end of concrete pipe. This setting collar is not designed to be a permanent item, but only an aid to installation. Anchor bolts may be needed on upper structural frame members and may be cast in place at time of pour, or expansion anchors may be used.

1. Place gate on pipe or opening inserting the taper collar until a snug fit is obtained or gate is stopped by the structure or pipe.
2. Align gate in a vertical and horizontal plane and place rich grout around gate, making a heavy band sealing and attaching the cast iron frame ring to the pipe. Grout is normally lapped over the frame flange and smoothed in place with laying mitts or gloves.

NOTE: If desired, anchor bolts or reinforcing rod can be attached in the anchor bolt holes and placed in the grout band for added strength.

3. After band has dried, check for cracks and repair as needed. Open gate and pack grout in void between collar and pipe.
4. Check gate for grout on seats or in slide grooves and clean as required.

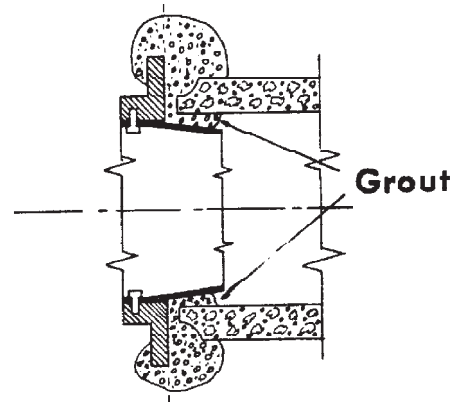

With galvanized steel taper setting collar
for concrete pipe, or headwalls (C-10c)
Figure 19

LUBRICATION RECOMMENDATIONS

1. Lubricate machined iron surfaces and bronze seats and wedging surfaces with Inertol Grease Coating, manufactured by Koppers, Inc., or equal.
2. Grease stainless steel seats and wedging surfaces with Never-Seez, manufacture by Never-Seez Corp. or equal. For best results mix Never-Seez with an equal portion of ten-weight oil.
3. Lubricate Waterman Gate Lifts with Zeniplex II, manufactured by Pennwalt Keystone Company or equal, at three month intervals. A one gallon can is a one to two year supply for three lifts.

NOTE: Use caution when filling pinion shafts on 3EP lifts. DO NOT OVERFILL.

FABRICATED SLIDE GATE INSTALLATION INSTRUCTIONS

FOREWORD

The purpose of this manual is to provide information to the contractors and associated personnel involved with installation and initial operation of equipment supplied by WATERMAN INDUSTRIES, INC. for this project. Although every care is taken in our factory to insure top quality equipment, we cannot be responsible for damage caused by negligence after shipping. Therefore, described herein are WATERMAN'S recommended methods of handling, storage, installation, adjustment and initial operation for standard situations, to be used in conjunction with the approved submittal drawings provided by WATERMAN INDUSTRIES, INC. If proper care and accuracy are exercised in the field when installing our gates, they will operate as designed at maximum efficiency. **IT IS RECOMMENDED THAT THIS MANUAL BE READ IN ITS ENTIRETY BEFORE ATTEMPTING STEP-BY-STEP INSTALLATION.**

THESE INSTRUCTIONS ARE DESIGNED FOR QUICK REFERENCE AND ARE INTENDED FOR GENERAL APPLICATIONS. THESE INSTRUCTIONS DO NOT SUPERSEDE THE INFORMATION CONTAINED IN THE O & M MANUAL HERETOFORE PROVIDED, AND SHALL NOT BE USED IN CONFLICT WITH SPECIFIC INSTALLATION NEEDS NOR PROPER INSTALLATION PROCEDURES.

IT IS THE SOLE RESPONSIBILITY OF THE JOBSITE ENGINEER AND/OR CONTRACTOR TO ASSURE THE PROPER STORAGE, HANDLING AND INSTALLATION PROCEDURE OF THE GATE AND ITS APPURTENANCES.

REVIEWING

CHECK COUNT all parts when you receive shipment. All individually shipped parts or assemblages are listed on the packing list. Should a shortage exist, notify WATERMAN INDUSTRIES immediately. We cannot be responsible for any shortages reported more than 30 days after receipt of shipment. Special care should be taken in accounting for and safely storing all bolts, nuts, and small items which are often misplaced at jobsites.

RECEIVING AND STORAGE

All WATERMAN gates and appurtenances are precision machinery and should be handled accordingly. While all parts are of rugged design, it is nevertheless possible to warp or damage machined surfaces, stems, etc., through improper storage and handling. To avoid all problems of this nature we recommend the following:

1. When any hoisting device is used to move, lift or install slide gates, be certain that:
The gate is properly supported so as not to damage the gate parts.
The stem should **NEVER** be used as a support.
2. Support **full** length of stems at all times if stem is separate from gate. Be sure not to damage threads.
3. Store equipment on an even, clean, dry surface to prevent distortion.
4. Cover all equipment to protect machined surfaces.
5. **DO NOT** stack equipment without protection.
6. Care for lifts as you would any precision machinery.

INSTALLATION INSTRUCTIONS - GENERAL

1. "Keep it straight." The gate, stem, stem guides and lift mechanism must always be perfectly aligned.

*SIDE RAILS TO BOTTOM RAIL
ANGLES MUST BE 90° TO ASSURE
COMPLETE SEATING OF SLIDE.*

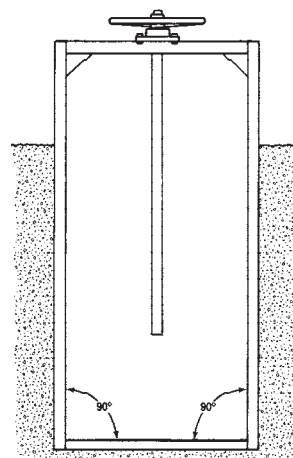
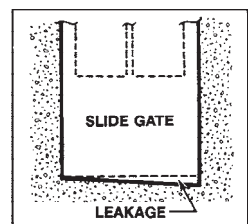

Figure 20



2. "Keep it clean." Assure that no concrete, grout or sealant is allowed to get into guide or seating areas or on stems.
3. "Keep it stress-free." Do not force gate or stem into stress or warpage conditions.

4. "Double-nut" the anchor bolts, pedestal and any other equipment that provides for and requires this type of mounting and alignment (plumb) adjustment. In these cases nuts should be placed in front of, and behind (or above and below) all mounting surfaces.
5. All unpainted aluminum in contact with concrete should be field painted prior to installation.

STOP !! BEFORE PROCEEDING TO GROUT STAGE, PLEASE READ THE FOLLOWING

- A. Keep seating surfaces flat! The flatter the sealing surface the better the sealing capability of the gate.
- B. Check flatness of seating surfaces and any flushbottom seals utilizing a straight edge with slide open, then with feeler gauge with slide closed **prior** to grouting gate into place. Frame bolts may be adjusted to bring frame and seating surfaces flat.
- C. If bowing in frame is unavoidable, a single span over a long distance is preferable to a 'wavy' span with several peaks and valleys. It is also preferable for any bow to be out away from wall rather than back towards it.
- D. Gates with metal to metal seats have no method for adjustment, therefore frame (and seating surface) flatness determines sealing capability. Frames should be flat within .010 over 24 inches.
- E. Gates with rubber J-Bulb seats should be held flat to within 1/16 inch over 24 inch span. This is especially true when there is a seal across top of gate and gate is subjected to unseating head.

NOTE - if insufficient compression exists on seal in center of gate, slide will pull away from seal under unseating head causing gate to leak. However, if excessive compression on protrusion out from frame exists, the slide will tend to pull seal out of its retainer. This is especially true on galvanized steel and stainless steel gates.
- F. Gates with ultrahigh molecular weight polyethylene (UHMW-PE) seals are built with slides that are more rigid than other slide gates. With cover open, the seals should be flat within .010 or less over 24 inch span when checked with straight edge. When gate is closed, a .002 inch feeler gauge should not be admitted between seats or flushbottom seal and slide.
 - (a) **Note** - 200 series gates do not have pressure bars or wedges. Bolts along side holding retainer bar are factory set between 20-35 ft. lbs. torque and should not be severely torqued down to attempt additional sealing due to an out of plumb frame.
 - (b) Sentinel Gates have side pressure bars and top wedges. Care must be taken when adjusting these items as it is physically possible to tighten adjusting bars and wedges to excess. When slide is properly adjusted, there should still be a small gap (1/16 to 1/64 inch) between back of UHMW-PE seat and frame, and no gaps where .002 inch feeler gauge can be admitted between top of seat and slide.

INSTALLATION OF SLIDE OR STOP GATE TO CONCRETE WALL

1. Secure all anchor bolts in proper position in forms, checking carefully to see that size, projection, perpendicular and horizontal alignments conform to requirements shown on our installation drawings. **EXTREME CARE** must be exercised in this initial procedure since bolts which are improperly set will cause gate warpage and therefore excess leakage between the seating surfaces. **DO NOT FORCE GATE ONTO MISALIGNED BOLTS.** An optional method of mounting could be with tap in concrete anchors or studs after wall is poured and cured and forms removed. Install concrete anchor per manufacturer's recommended procedure, insuring stud projections are as shown on drawing. Use guide rail as template. Double nut anchors per following instructions (2).

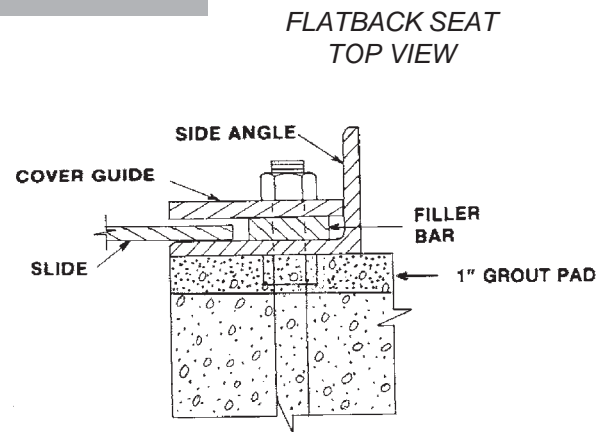

Figure 21

2. The preferable procedure is to "double-nut" the anchor bolt; i.e., provide a nut below the frame or flange mounting for plumb adjustment in addition to the securing top nut. This requires a blackout for later grouting. The nearby figures and the submittal drawings show this type of installation. In this manner, vertical and horizontal plumb can be assured by adjusting the nuts before filling the blackout with grout. Make certain the grout is of the non-shrink type.
3. If the above procedure is not used, it is very important that each mounting nut be tightened a small amount each time until the guide, frame or flange touches the wall initially. The guide should be checked to insure that both legs are parallel and plumb. At this time the need for shims or sealant will be apparent. The wall-mounted guide frame **must** be set plumb and straight regardless of the condition of the vertical concrete wall on which it is to be mounted. Do not induce warping during final tightening of the bolts.

INSTALLATION OF SPIGOTBACK GATES TO CONCRETE WALL

Spigotback gates are installed in the same manner as flatback gates specified above, with the following additions:

1. When setting the anchor bolts in the form, form a blockout for spigot to dimensions specified in drawing.
2. After gate is installed, and nuts tightened on bolts, grout in voids around spigotback with a dry pack concrete mix or a non-shrink grout.

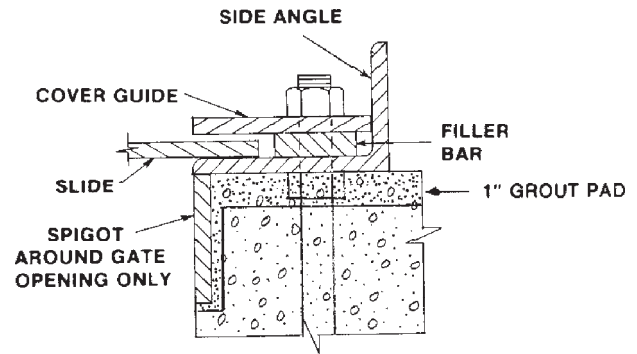

Figure 22

INSTALLATION OF SLIDE GATES WITH J-BULB SEALS

Follow same procedure as for spigotback or flatback gates as described above, with the following additions:

Check clearance between seal and slide following installation with a .002 inch feeler gauge. Gauge should not pass at any point around seal perimeter with gate in fully closed position. If adjustment of seal is necessary, refer to page 20 of this manual, "Procedure for replacing and adjusting J-bulb seals for fabricated slide gates." All gates with "J" seals will have flushbottom seals unless the gate is a downward opening weir type. Start the checking process across the flushbottom seal - then proceed to the sides and top.

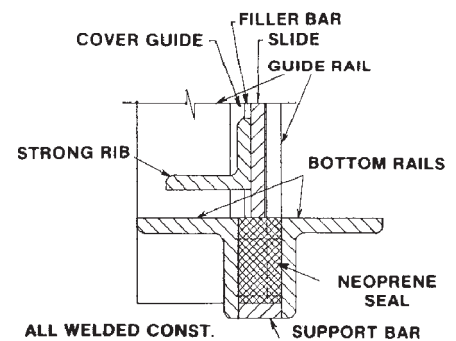

Figure 23

INSTALLATION OF EMBEDDED SLIDE OR STOP GATE

A gate and its guide frame are normally shipped with the slide (cover) in the guide and the assembly banded together, thus forming a compact factory-aligned unit. Two methods are available for installation:

OPTION 1: INSTALLING GATE AT TIME OF CONCRETE POUR

This must be done with slide removed and can only be done in a channel mount.

1. Place the gate in a vertical and plumb position in the forms, and secure in place. Use timbers or other bracing on the inside of the opening to support the gate and prevent warpage during the pour. This is especially true on large gates.
2. Pour concrete, being **EXTREMELY CAREFUL** not to get any concrete in guide area.
3. After concrete has cured, remove forms and bracing. Thoroughly clean gate and guide of any concrete splash or splatter.

OPTION 2: INSTALLING GATE AFTER CONCRETE POUR

1. Form blockout in concrete to dimensions specified on installation drawing. Blockout should be designed in such a manner that dry pack or grout will lock into parent concrete.
2. After concrete has cured and forms have been removed, align gates in blockout, insuring gate is vertical and plumb.
3. Secure gate into place with non-shrink grout.
4. After grout has hardened, thoroughly clean gate and guide.

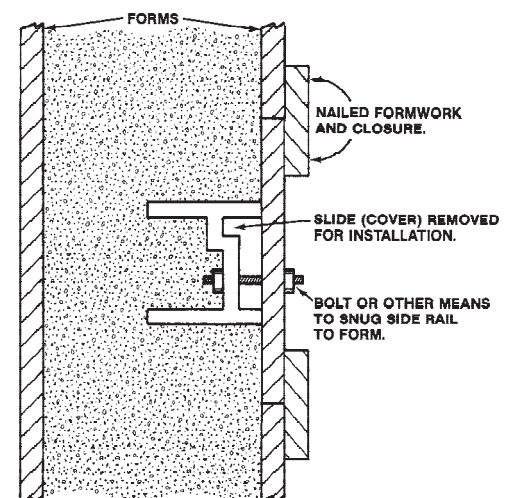

PLAN (TOP) VIEW OF TYPICAL METHOD OF EMBEDDING SLIDE GATE. ONLY ONE SIDE RAIL SHOWN. BOTTOM RAIL REQUIRES SIMILAR FORMING. TOP HEAD RAIL NOT NORMALLY IN CONCRETE.

Figure 24

PROCEDURE FOR INSTALLING STEM & STEM GUIDES (NON-SELF CONTAINED GATES)

1. Stems are shipped with limit nuts and couplings attached; these must be removed prior to installation. Stem connector bolt is attached to the gate cover and should also be removed.
2. After the gate has been mounted, lower drilled end of stem through head or cross rails and into stem connector bracket in gate slide.
3. Insert stem connector bolt and tighten nut.
4. Mount stem guides as stem is installed. Do not tighten stem guide assembly bolts. If stem guides are not the split type the guide portion must be assembled on the stem when lowered into place.
5. Install stem couplings as required, being sure to install keys, to tighten all set screws, or to drive in pins as required.
6. Take care not to bend stems or damage threads during installation.
7. Thoroughly clean and grease stem threads with heavy duty grease, such as Lubriplate, Mobilux grease #2EP or equal. (See maintenance section in O & M manual for equivalent greases.)

PROCEDURE FOR INSTALLING MANUALLY OPERATED LIFT (PEDESTAL TYPE)

Lifts are factory lubricated, and do not need lubrication at time of installation.

INSTALLATION ON OPERATING FLOOR (non self-contained gate)

1. Place one nut on each anchor bolt and thread it down against operating floor.
2. After assembling stem*, lower the lift over the upper threaded portion of stem carefully engaging threads of lift nut and stem. With electric motor operators in particular, the lift nut may be removed, and pedestal set over stem. Replace lift nut.

*If a limit nut is to be used to stop upward gate travel, it must be installed on the stem prior to installing the lift. (See page 19).

3. Bring base of lift over anchor bolts to about 1" from floor by rotating handwheel or crank and adjust lower nuts until proper vertical alignment is achieved.
4. Place and tighten top nut on anchor bolts against pedestal base flange and grout flange in place.
5. Once the lift is properly installed, apply tension to the stem with the lift and align the stem guides. Tighten stem guide assembly bolts.

INSTALLATION ON TOP WALL MOUNTING BRACKET

1. Mount top wall mounting bracket on anchor bolts, and secure with nuts. Top surface of bracket must be aligned perpendicular* with stem, and stem must pass approximately through center of stem slot.

*If wall face or top is unduly rough or badly out of plumb, wall may need to be grout-faced to provide proper mounting surface for bracket.

2. After assembling stem*, lower the lift over the upper threaded portion of stem carefully engaging threads of lift nut and stem.

*If a limit nut is to be used to stop upward gate travel, it must be installed on the stem prior to installing the lift. (See page 19).

3. Bring base over top of bracket and mount with four bolts and nuts. Adjust floorstand until proper alignment is achieved. Tighten bolts.
4. Once the lift is properly installed, apply tension to the stem with the lift and align the stem guides. Tighten stem guide assembly bolts.

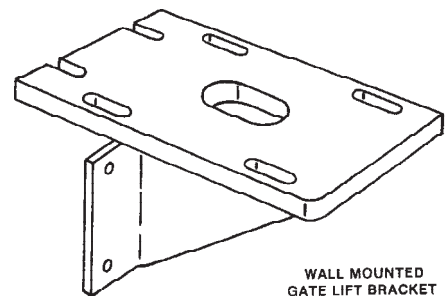

INSTALLATION OF ELECTRIC LIFTS

1. Install motor operated lifts in same manner as the manual lifts described previously. Make certain that if any limit nuts are used they do **not** bottom out before activating limit switches.
2. **IMPORTANT:** Alignment of lift and stem is of critical importance. Double check all components (stem, stem guides, brackets, pedestal, lift, etc.) to insure all are perfectly aligned.
3. USING MANUAL HANDWHEEL, OPEN GATE A MINIMUM OF THREE (3) INCHES PRIOR TO USING ANY ELECTRICAL CONTROLS. DOUBLE CHECK HANDWHEEL FOR PROPER ROTATION INDICATION.

4. Connect electrical power and any remote wiring in accordance with wiring diagrams. During wiring installation, should it become necessary to leave unit, close and tighten limit switch compartment and any open conduit taps so as not to leave electrical components unprotected from elements.
5. With gate open minimum of 3 inches, electrically operate gate to check for proper rotation and wiring. By having gate open, the direction of rotation can be checked without damaging the stem, stem cover or hoisting unit should gate move in wrong direction. If gate direction is incorrect, stop immediately and consult manufacturers instructions.
6. Once the unit has been installed, the manufacturer's directions should be followed closely in setting the closing and opening travel limit switches (See Field Adjustment). The torque switches have been properly set at the factory and should not need adjustment. Follow the manufacturer's instructions if it appears that adjustment is necessary.
7. Lifts are factory lubricated and do not need lubrication at the time of installation.

PROCEDURE FOR INSTALLING TANDEM LIFTS (PEDESTAL TYPE)

1. Mount the lifts as described for manual lifts, steps 1-3.
2. Install U-joints and interconnecting shaft between the two pedestals. Leave set screws a little loose for adjustments.
3. Measure distance from floor to shaft centerline. Adjust nuts on anchor bolts to ensure that both pedestals are level, and that the interconnecting shaft is level.
4. Tighten set screws on universal joints.
5. Proceed with steps 4 and 5 for manual lifts.

INSTALLATION OF LIMIT NUTS AND STEM COVERS

1. **IMPORTANT:** In those cases where a limit nut is used to stop **upward** gate travel, and pedestal lift is also used, limit nut must be installed on stem prior to installing lift.
 2. After lift is installed, fully close gate.
 3. Screw **downward** travel limit nut on stem until it just starts to bottom out on top of lift nut. *
- * If gates have wedges which require adjustment, final setting and tightening of limit nut will have to be done after gate wedges are adjusted.
4. Screw stem cover into threaded bracket on top of lift. A thread sealant should be used on threads. Cover should be approximately 4 inches longer than gate height (stem travel).

INITIAL OPERATION OF GATES

1. After gate, stem guides, stem lifting mechanism, and other necessary apparatus have been installed, check the following prior to operation:
 - a. Check all assembly and mounting hardware for proper tightness.
 - b. Apply tension to stem and check for proper alignment.
 - c. Remove any shipping stops on gates.
 - d. Check gate guide grooves for any foreign matter, and clean as necessary.
2. If not done previously, or if gate stem has set some time after installation, thoroughly clean stem threads and lubricate * in accordance with stem installation instruction. (* See page 18, Note 7.)
3. Open gate slide to fully open position.
 - a. For manually operated lifts, turn handwheel or handcrank in direction noted on handwheel or on lift housing.
 - b. Gates moved by electric actuators normally have open & close push-buttons mounted on the actuator housing. After checking items 3, 4, 5, & 6 under "Installation of electric lifts", and with gate in the closed position, move gate open by pushing the "open" push-button. The gate should start toward the open position - the button can be released and the gate should continue to the full open position where the travel limit switch should automatically stop gate travel. Push the "close" button. The reverse travel should occur until the gate stops automatically in the closed position.

4. Clean all dirt, paint, concrete splatter, or other foreign material from seating surfaces, wedges, flushbottom seals, etc.
5. Seating surfaces of aluminum or fiberglass slide gates, including gates with UHMW polyethylene bearing strips require no lubrication.
6. Close gate completely and check for proper closure. (See "**CAUTION**"). On fabricated slide gates, check to see slide fits flat against seating surface. Check to be sure frame is not warped.
CAUTION: Be extremely careful when closing gate so as not to apply excessive compressive force on stem. The stem under a compressive load is the weakest link in the system and can buckle (bow) if excessive force is applied to operator.
7. Set any limit nuts or position indicators as required per applicable instructions.
8. Cycle gates with operators to insure proper installation, alignment, and operation.

PROCEDURE FOR REPLACING AND ADJUSTING J-BULB SEALS FOR FABRICATED SLIDE GATES

1. Adjustment on J-Bulb seals are made at factory and should not need to be field adjusted, but if adjustment is necessary, carefully note the following instructions:

- a. To adjust J-Bulb seal, slide should be in the fully closed position. Begin by checking clearance between seals and slide with a .002 inch feeler gauge around entire perimeter, noting any points which allow passage of the gauge. Loosen hex head machine bolts adjacent to points requiring adjustment just enough to allow the seal to be moved. Push seal against the slide until feeler gauge will not enter, retighten bolts. Recheck entire perimeter and readjust if necessary.
- b. To replace J-Bulb seal, remove hex head machine bolts, nut plate seal retainer, and J-Bulb seal, carefully noting the position of each. Remove old J-Bulb seal and replace with new seal and assemble with seal retainer nut plate and hex head machine bolts, being careful not to overtighten bolts. To adjust new seal, follow instructions in paragraph "a".

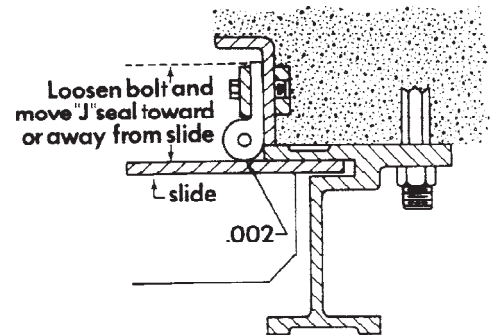

"J" BULB SEAL ADJUSTMENT (TOP VIEW)
ONE SIDERAIL ONLY PICTURED

Figure 26

PROCEDURE FOR ADJUSTING SIDE PRESSURE BARS ON SENTINEL SLIDE GATES (FLATBACK MODEL SHOWN, OTHER MODELS SIMILAR)

A. TO INCREASE SEAT PRESSURE:

1. Loosen adjusting stud lock nut, (B).
2. Tighten outer nut (A) slightly until proper seating is attained.
3. Tighten locking nut, (B).

B. TO DECREASE SEATING PRESSURE:

1. Loosen nut, (A).
2. Tighten nut (B) slightly until proper seating is attained.
3. Tighten nut (A).

CHECK SEAT CLEARANCE AROUND FULL PERIPHERY. A .002" FEELER GAUGE SHOULD NOT PASS BETWEEN SEATS OR BETWEEN GATE BOTTOM AND BOTTOM SEAL. READJUST AS NECESSARY.

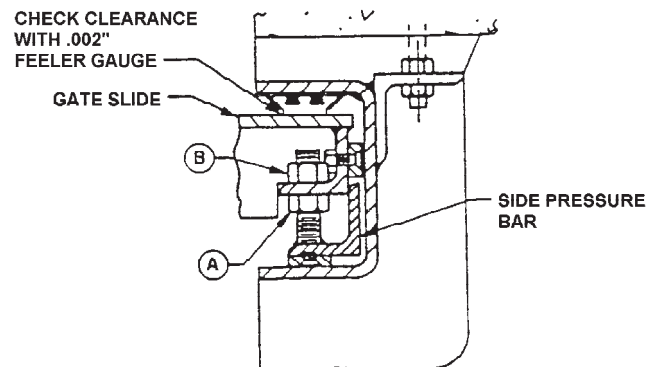

Figure 27

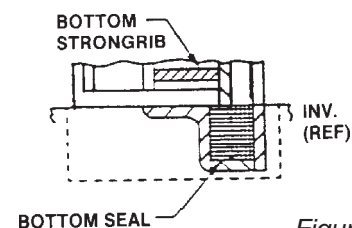

Figure 28

PROCEDURE FOR ADJUSTING TOP WEDGE ON SENTINEL & SLIDE GATES

Check seat clearance with .002" feeler gauge. If seats allow insertion of gauge follow Procedure A. If seats are binding, follow Procedure B.

Figure 29

A. TO INCREASE SEAT PRESSURE:

1. Loosen locking nut, (A).
2. Tighten adjusting nut (B) slightly until proper seating is attained.
3. Tighten locking nut, (A).

B. TO DECREASE SEATING PRESSURE:

1. Loosen nut, (B).
2. Tighten nut (A) slightly until proper seating is attained.
3. Tighten nut (B).

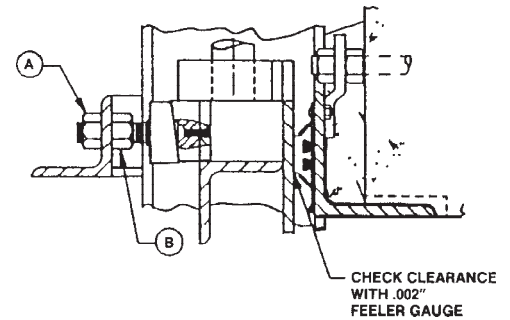

WEDGE SHOULD NOT BE ADJUSTED IN SO FAR AS TO PREVENT THE GATE BOTTOM FROM DEPRESSING THE BOTTOM SEAL. TO DO SO COULD CAUSE GATE DAMAGE.

PROCEDURE FOR SETTING COUNTER POSITION INDICATORS (MANUAL LIFTS)

1. A manually operated lift with counter position indicator, must be field set after gate is installed and adjusted.
2. After the lift has been properly installed, lower the gate until the slide just touches the bottom seal (or top seal for weir gates). This is the point of zero opening.
3. Remove counter housing and lift counter enough to disengage gears.
4. Set the indicator to zero and replace it on the lift, making sure that as the gears are engaged the indicator does not move from zero.
5. Note that in the full wedging position, the indicator will read less than zero.
6. If preferred, counter can be set at zero when gate is in closed position.

PROCEDURE FOR SETTING DIAL TYPE POSITION INDICATORS (MANUAL LIFTS)

1. Indicator must be field set after gate, stem, and lift are installed and adjusted. Indicator and gearing does not need to be disengaged when installing lift.
2. After the lift has been properly installed, lower the gate until the bottom seating surface of the cover just meets the bottom seating surface of the frame. This is the point of zero opening.
3. Remove four (4) screws holding dial cover plate and remove plate, being careful not to lose o-ring seal.
4. Loosen set screw in dial indicator, using 5/64 inch shortarm allen wrench. Rotate dial indicator until pointer aligns with last dial marking with "C" (closed) next to it. Retighten set screw.
5. Operate gate through one cycle (or at least minimum ¼ open) to insure dial indicator turns freely and returns to set position when gate is closed. Reinstall cover plate.
6. Note that when gate is in fully wedged position, the dial indicator pointer will align slightly below dial marking. If desired, dial indicator can be set to align with closed dial marking when gate is fully wedged.

PROCEDURE FOR SETTING CLEAR PLASTIC STEM COVER INDICATORS

1. Indicator strips are attached after the lift and stem cover have been installed and the gate has been adjusted for proper seating.
2. Be certain that the stem is clean and dry, inside and out. Use mild detergent or commercial cleaners specifically made for plastic.
3. Observe through the stem cover where the top of the stem is positioned when the gate is fully closed. Make a small mark on the outside of the stem cover at this point. This is your "zero" reference.
4. The mylar strip is graduated in increments with "0" at the bottom. Peel off the paper backing (the mylar strip is self-adhesive) then starting at the "zero" reference attach the mylar strip, taking care to avoid bubbles and wrinkles.
5. Cut off any excess strip that extends past the pipe cap.

MAINTENANCE OF OPERATING STEMS

1. It is critical that operating stems be periodically cleaned and greased. Even though some environmental conditions are harsher than others and the use of pipe covers will protect stems, they still need to be cleaned and greased with Mobilux grease #2EP or equal * at least once every six (6) months. More often if the grease becomes dirty.
 - * See lubrication chart in O & M manual for equivalent lubricants.
2. **WARNING!!!!** Non-rising stem gates generally require a special maintenance program. If the level of the water or sewage rises above the top of the opening, the threads on the stem may become coated with grit. Under this condition, frequent use of the gate will wear the threads in the thrust nut creating a dangerous and possibly damaging condition. Therefore the following maintenance procedure should be followed:
 - a. If practical, the stem should be kept clean and greased.
 - b. If the gate is cycled on the average of once a week, the thrust nut should be removed every year and inspected for wear. (More frequently after the first signs of wear or if the frequency of operation is greater or the conditions are very severe.)

MAINTENANCE OF GATE OPERATORS

1. At least three (3) times a year, all grease fittings on manual floor stands should be lubricated with a small amount of good quality, long fiber cup type grease. (See lubrication chart for some recommended lubricants.)
2. **CAUTION:** DO NOT OVERFILL when filling pinion shafts of manual 3EP series lifts. Handwheels or cranks should be in motion while grease is being applied through the grease fitting. 3 to 5 pumps of a standard hand-held grease gun per fitting should be an adequate amount of grease for any one lubrication period.
3. For electric motor operated or cylinder lifts see separate manufacturers O & M manuals.

SEAL REPLACEMENT FOR A-200 AND SS-200

Square and Rectangular Opening Gates (seals on sides, top and bottom).

1. Remove item hex head bolt and nut.
2. Remove retainer bar, cover guide, slide and spacer.
3. Remove retainer bar, round head screw and hex nut.
4. Bearing strip and cross rail seat must be removed together as one assembly.
5. Remove flushbottom seat.

Reinstall seats and seals in opposite order.

Channel Mounted Gates (seals on sides and bottom)

Follow items 1 through 3 and 5 above.

Downward Opening Gates (seals on sides and bottom only)

Follow items 1 through 4 above.

Downward Opening Gates (seals on sides, bottom and top)

Follow items 1 through 5 above.

- (1) Frame Weldment
- (2) Slide Weldment
- (3) Seal
- (4) Bearing Strip
- (5) Spacer
- (6) Cover Guide
- (7) Retainer Bar
- (8) Hex Nut
- (9) Hex Head Bolt
- (10) Flushbottom Seat
- (11) Crossrail Seat
- (12) Retainer Bar
- (13) Round Head Screw
- (14) Hex Nut

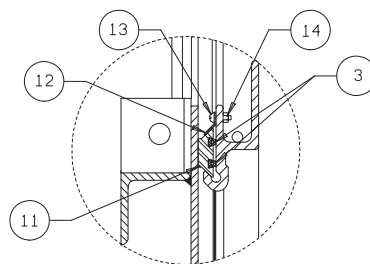

Detail C
Figure 31

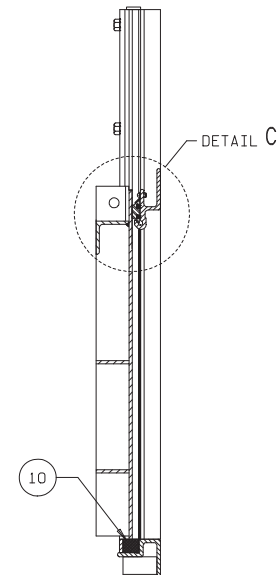
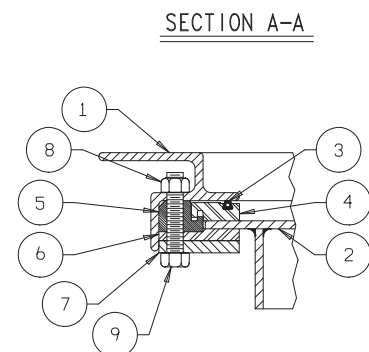

Figure 30



Section through Guide Rail
Figure 32

AUTOMATIC DRAINAGE GATE INSTALLATION INSTRUCTIONS

FOREWORD

The purpose of this manual is to provide the contractor with pertinent information for the proper installation of our automatic drainage gate. Although every care is taken in our factory to insure top quality equipment, we cannot be responsible for damage caused after shipping. Therefore, described herein are Waterman's recommended methods of installation, handling, storage, and adjustment for standard situations, to be used in conjunction with the approved installation drawings provided by Water Industries, Inc. If proper care and accuracy are exercised in the field when installing our gates, they will operate as designed at maximum efficiency.

RECEIVING, HANDLING AND STORAGE

✓ **Check count** on all parts upon receipt of a shipment, noting any shortages immediately. We cannot be responsible for shortages reported after any lengthy delay. Special care should be taken in accounting for and safely storing all bolts, nuts and small items which are often misplaced at jobsite. Waterman double counts these parts to assure accuracy.

All Waterman gates and appurtenances are precision machined and should be handled accordingly. While all parts are of a rugged design, it is nevertheless possible to warp machined surfaces through improper storage and handling. To avoid all problems of this nature we recommend the following:

1. Support gate carefully at all times when moving, taking particular care of seat faces.
2. Store equipment on an even, clean, dry surface to prevent distortion.
3. Cover all equipment when in storage to protect machined surfaces.
4. DO NOT stack equipment.

INSTALLATION INSTRUCTIONS FOR AUTOMATIC DRAINAGE GATES

- (1) Frame
- (2) Cover
- (3) Pivot Lug
- (4) Hinge Link
- (5) Hinge Stud
- (6) Hinge Nut
- (7) Hinge Pin
- (8) Hinge Bushing
- (9) Washer
- (10) Spring Pin
- (11) Set Screw
- (12) Jam Nut

Figure 33

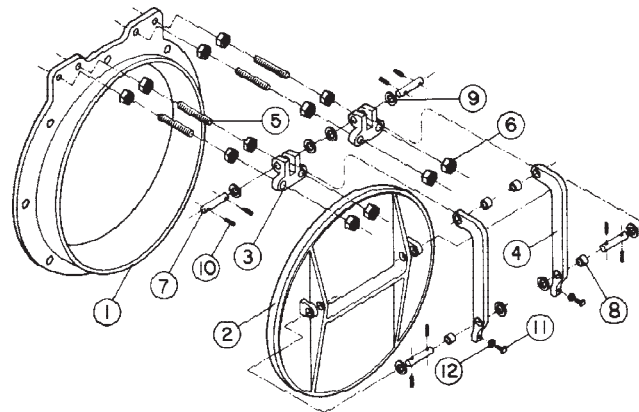

PROCEDURE FOR INSTALLING A FLATBACK GATE ON A CONCRETE HEADWALL

1. Secure all anchor bolts in proper position in the forms, checking carefully to see that size, projection, perpendicular and horizontal alignments conform to requirements shown on our installation drawing. Extreme care must be exercised in this initial procedure in that bolts which are improperly set will cause gate warpage and therefore excess leakage between the seating surfaces. DO NOT FORCE GATE ONTO MISALIGNED BOLTS.
2. Each bolt has been provided with two nuts to facilitate proper mounting of the gate. In setting the forms, sufficient grout space must be left for adjustment of the back nut as shown in Figure 34.
3. After concrete has been poured and the forms have been stripped, place one nut on each anchor bolt then slip gate into place over anchors. (Again we must reiterate, DO NOT FORCE GATE ONTO MISALIGNED BOLTS, See Figure 34.) Place the second nut on each bolt and bring both front and back nuts into finger-tight contact with gate frame, aligning it as necessary. Make sure gate seats and joints are clean. At this point, check for excess clearance between seating surfaces with .004" feeler gauge. In the event

that the gate is not seating properly, check to see if gate has been warped during installation. If so, adjust nuts on anchor bolts to bring frame into flatness.

4. After gate is found to be seating properly, carefully drypack or grout between frame and headwall using a non-shrink material. Check for voids after it has set and fill as necessary.
5. Lightly tighten all nuts on anchor bolts uniformly, taking care not to warp gate to conform to uneven surface.
6. Adjust pivot lugs (if applicable). See section on gate sensitivity.
7. Lubricate bushings when fittings are provided. Gate is now ready for operation.

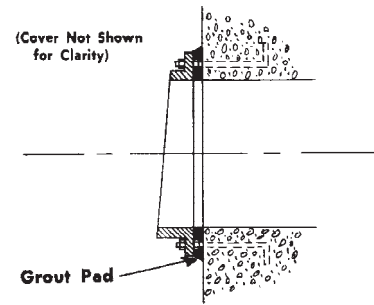

Figure 34

PROCEDURE FOR INSTALLING A FLATBACK GATE ON A WALL THIMBLE OR PIPE FLANGE

1. Place the thimble in correct position in the forms and secure in place. The top is marked on the flange face and should be aligned with a plumb. If a standard 25# or 125# flange mount has been specified, studs should be screwed into two top holes (on each side of center-line). Place carpenter's level on these two studs and rotate thimble until tops of studs are level. Thimble should be flush or projecting slightly from the headwall face.
2. Use timbers or other bracing on the inside of the opening to support the thimble and prevent warpage during the pour. This is especially important on large thimbles or when the concrete will be especially high.
3. Plug the tapped holes in the thimble with the studs provided or other removable plugs that will prevent concrete from entering the tapped holes.

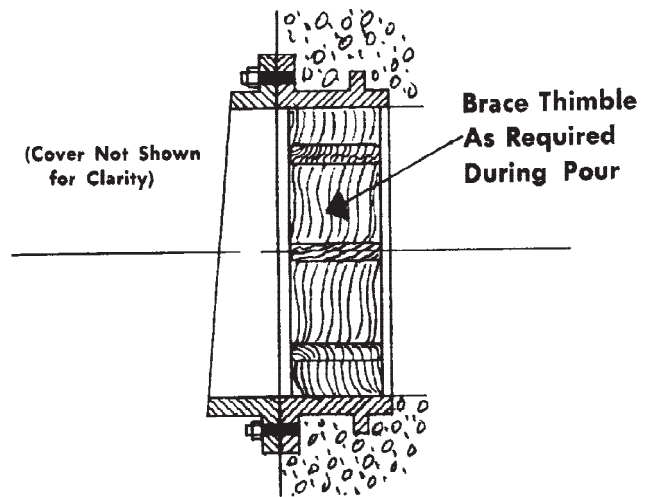

Figure 35

4. Pour concrete, using care not to tilt or move thimble from its original position in the forms.
5. Let concrete set, then remove forms and bracing. Thoroughly clean the front machined face of the thimble and place cleaned studs into tapped holes provided.
6. Clean the back of the gate frame thoroughly. Apply a thin coat of mastic (such as butyl rubber compound or black asphaltic compound) on the front face of the thimble.
7. Mount the completely assembled gate on the thimble. Place nuts on studs and tighten uniformly until a metal to metal contact is made, removing excess mastic. Make sure gate seats and operating joints are clean.
8. Check clearance between seating surfaces with .004" feeler gauge. One cause of improper seating is warpage of gate frame due to mounting on a thimble which has been warped during the pouring of the concrete. If steps one through five are strictly adhered to this will be avoided and the mounting of the gate will be a simple procedure.
9. Adjust pivot lugs (if applicable). See section on gate sensitivity.
10. Lubricate bushings when fittings are provided. Gate is now ready for operation.

PROCEDURE FOR INSTALLING A SPIGOTBACK GATE ON CORRUGATED PIPE

1. Place spigotback gate over pipe end.
2. Drill pipe through holes provided in spigot (13/32" or 7/16" drill bit).
3. Secure gate to pipe with galvanized steel or brass rivets or bolts. **DO NOT FORCE THE BOLTS OR RIVETS.**
4. Apply a sealant (hot tar or other mastic) to the joint between gate and pipe, inside and out.
5. Brace inside of pipe. **DEFLECTION OR DISTORTION OF THE ATTACHED PIPE SECTION MAY CAUSE WARPAGE OF GATE SEAT AND LEAKAGE.** This is particularly true of larger gates.
6. Place coupled gate and pipe in form of ditch and backfill or pour as required, making sure that gate frame is vertical and that links are equidistant from vertical centerline of opening. Gate seats are angled 2½° to 5° from the vertical plane to prevent gate from

hanging open should the installation be slightly off vertical or due to subsequent settling of pipe.

7. Remove bracing and clean gate seats and operating joints. Check to see that seats make proper contact around full periphery of gate. (Use .004" feeler gauge.)
8. On those gates with adjustable hinge brackets make adjustments until desired sensitivity is attained. (See section on gate sensitivity.)
9. Lubricate bushings when fittings are provided. Gate is now ready for operation.

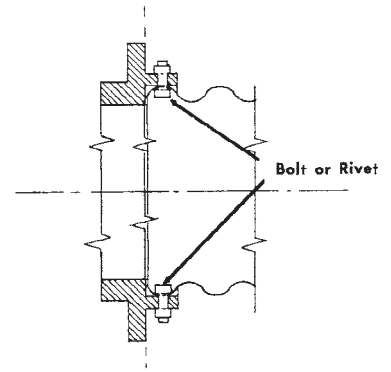

*"sb" Spigotback for annular or spiral corrugated pipe.
Figure 36*

ATTACHING GATE TO CONCRETE PIPE WITH TAPER SETTING COLLAR

The light gauge galvanized taper setting collar is used as a "form" for placing grout and as a means of locating a gate in the end of concrete pipe.

1. Place gate on pipe or opening inserting the taper collar until a snug fit is obtained or gate is stopped by the structure or pipe.
2. Align gate in a vertical and horizontal plane and place rich grout around gate, making a heavy band sealing and attaching the cast iron frame ring to the pipe. Grout is normally lapped over the frame flange and smoothed in place with laying mitts or gloves.

NOTE: If desired, anchor bolts or reinforcing rod can be attached in the anchor bolt holes and placed in the grout band for added strength.

3. After band has dried, check for cracks and repair as needed. Open gate and pack grout in void between collar and pipe.
4. Check gate for grout on seats or in slide grooves and clean as required.

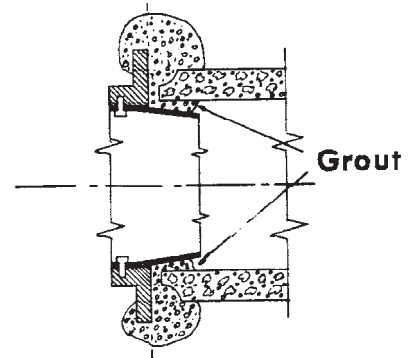

*With galvanized steel taper setting collar for concrete pipe, or headwalls (F-10C)
Figure 37*

PROCEDURE FOR CONTROLLING SENSITIVITY OF ADJUSTABLE DRAINAGE GATES

(Models F-20, F-25, F-40 and F-55 only)

The sensitivity of a drainage gate is determined by the location of the upper pivot in relation to the flap pivots. The gate is most sensitive when the pivots are adjusted forward to a point where further forward movement would cause the gate to open. As the pivot lugs are moved toward the frame the sensitivity decreases. Procedure for adjustment is as follows:

1. To increase sensitivity, loosen front nuts on lugs and move them out to desired position.
2. Move back nuts forcing pivot lug out against front nuts. Both lugs should be parallel after adjustment.
3. Loosen lock nuts on hinge set screws.
4. Adjust set screws in or out until seating surfaces are aligned.

NOTE: To decrease sensitivity, reverse the procedure described above.

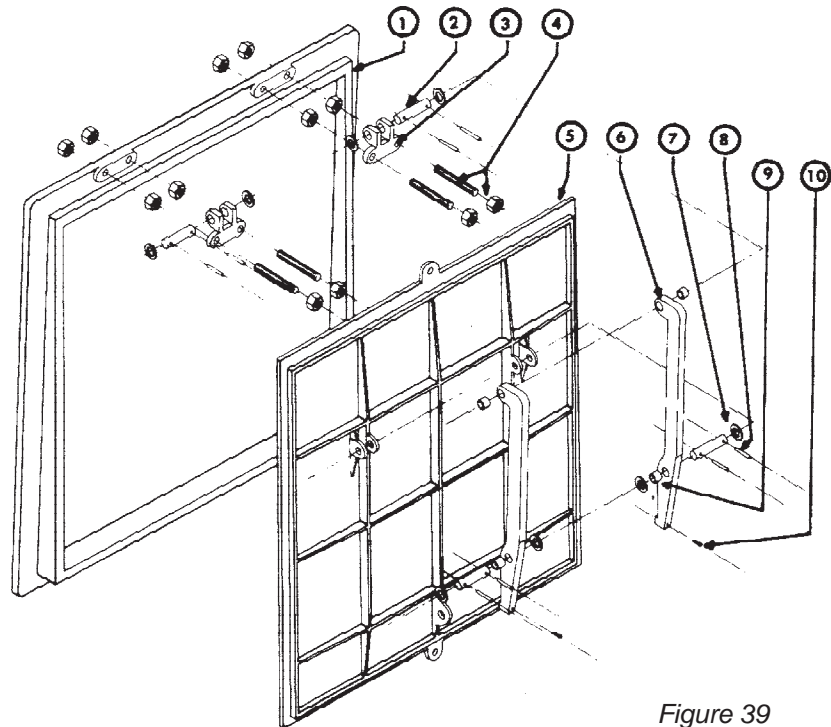

- (1) Frame (Flat or Spigotback)
- (2) Hinge Pins
- (3) Adjustable Hinge Bracket (Pivot Lug)
- (4) Studs and Stud Nuts
- (5) Cover Flap
- (6) Link
- (7) Washer
- (8) Retaining Spring Pin
- (9) Bushing
- (10) Set Screw

Figure 39

DRAINAGE GATES (NONADJUSTABLE) MODEL F-10, FC-10, PF-25, AF-41 AND F-50

INSTALLATION:

FLATBACK (OR FLANGEBACK)

Thin b~~e~~ or pipe flange.

1. Install studs in flange.
2. Apply mastic or rubber gasket.
3. Mount gate.
4. Install nuts on studs and tighten.

Anchor Bolts

1. Anchor bolts should project from the wall a sufficient amount to allow for a one inch grout pad between the gate frame and the wall.

2. Thread one nut on each anchor.
3. Mount gate on the anchors.
4. Thread another nut on each anchor.
5. Use the double-nut system to bring gate into plumb and level. Avoid warping the frame.
6. Complete the installation by packing a non-shrink grout between the frame and the wall.

SPIGOTBACK GATES

Bolt gate to pipe using predrilled holes in spigot as a guide. Bolted connections usually require a sealant between pipe and gate to make a watertight connection.

Adjustment

These gates are factory adjusted and require no field adjustment.

Service

A regular lubrication schedule is not necessary. These gate usually require no maintenance.

SPECIALTY PRODUCTS INSTALLATION INSTRUCTIONS

FOREWORD

The purpose of this manual is to provide the contractor with all pertinent information for the proper installation of our specialty equipment. Although every care is taken in our factory to insure top quality equipment, we cannot be responsible for damage caused by negligence after shipping. Therefore, described herein are Waterman's recommended methods of handling, storage, installation, adjustment and initial operation for standard situations, to be used in conjunction with the approved installation drawings provided by Waterman Industries, Inc. If proper care and accuracy are exercised in the field when installing our equipment, they will operate as designed at maximum efficiency.

RECEIVING, HANDLING AND STORAGE

✓ **Check count** on all parts when you receive a shipment, noting any shortages immediately. We cannot be responsible for shortages reported after any lengthy delay. Special care should be taken in accounting for and safely storing all bolts, nuts, and small items which are often misplaced at jobsites. Waterman double counts these parts to assure accuracy.

All Waterman gates and appurtenances are precision machinery and should be handles accordingly. While all parts are of a rugged design, it is nevertheless possible to warp machined surfaces, stems, etc., through improper storage and handling. To avoid all problems of this nature we recommend the following:

1. Handle equipment with care. Avoid damaging machined flanges. Do not drop or walk on this equipment.
2. Support full length of stems at all times, being sure not to damage threads.
3. Store equipment on an even, clean, dry surface to prevent distortion.
4. Cover all equipment to protect machined surfaces.
5. Do not stack equipment without protection.
6. Handle lifts as you would any precision machinery.

MODEL MV-11 MUD VALVES

INSTALLATION:

1. Mount valve on pipe flange with mastic or rubber gasket.
2. Install stems, guides, lifts, and/or floorboxes as indicated on the submittal drawing.
3. Be sure that the operating stem or extension stem is vertical and plumb.
4. Level the floorstand (if used).

LUBRICATION:

1. Handwheel lifts that are equipped with grease fittings should be lubricated every 3 month with mobil #3EP or equal.
2. Handwheel lifts that are not equipped with grease fittings do not require lubrication.
3. The mud valve requires no lubrication or service.

OPERATION:

The handwheel of 2" square operating nut will have a directional arrow for the "open" movement. Operate the handwheel or "T" handle as needed.

TELESCOPING VALVE

INSTALLATION:

1. Attach gasket and retaining flange to pipe flange.
2. Insert valve body into gasket. Grease or a cardboard "funnel" may be used to aid in installation. Take care to not tear the gasket.
3. Install stem and stem guides (or rack) as shown on the submittal drawing.
4. Level the floorstand as required.

5. Be sure that the stem (or rack) is plumb, and set the limit nuts.
6. With the valve in the full down position, the mylar indicator may now be attached to the stem cover (if included with valve).
7. Usually, when the valve is in the full "up" position, one "diameter" of the valve body will remain below the gasket.

LUBRICATION:

1. Lift assemblies that are equipped with grease fittings should be lubricated every 3 months with mobil #3EP or equal.
2. Lifts without grease fittings, including type 5 OP rack and pinion lifts, require no lubrication.
3. Stem threads should be greased every 4 months.
4. Racks require no lubrication.
5. The valve requires no lubrication.

OPERATION:

The handwheel will have a directional arrow and the word "open" on the rim. Rotate the handwheel as necessary.

If the valve is equipped with an electric motor operator consult the manual that was provided with the operator.

If equipped with rack and pinion lift, turn handwheel to raise. To lower, release pawl and turn handwheel.

MODEL C-7 AND C-16 SHEAR GATES

INSTALLATION:

1. Attach the gate to the flange. A mastic or rubber gasket is recommended between the frame ring and the pipe flange.
2. The lift rod is equipped with an adjustable lug. A bracket should be provided for the lug to hook onto to hold the cover open.
3. Closure is accomplished by lowering the cover onto the wedges on the frame.

MAINTENANCE:

Shear gates require no service or lubrication.

PRESSURE RELIEF VALVES

FLOOR TYPE - PRF-14

INSTALLATION:

1. Locate in forms as required. The top flanges should be flush with or slightly above the finished floor.
2. Protect the seats from foreign materials.
3. Place the concrete or grout in position.
4. Warning - the seats are easily damaged. Do not walk on or place equipment on these valves.
5. Be sure seats are clean and not deformed before placing the valves into service.
6. No maintenance or lubrication is required.

WALL TYPE - PRB-14

INSTALLATION:

1. Mount valve on pipe flange using a rubber or mastic gasket between the valve and flange.
2. Be sure mounting flange is plumb.
3. Be sure seats are clean and undamaged before placing the valve into service.
4. This valve is factory set and is not adjustable for sensitivity.

MAINTENANCE:

1. No maintenance or lubrication is required.

STOP GATES

INSTALLATION:

WALL MOUNTED TYPE

1. Bolt frame to the wall as required with a mastic gasket between the frame and wall.
2. Check to be sure the frame is square, vertical and plumb.
3. Slide plate should move freely without binding.

EMBEDDED TYPE

1. Brace frame in blockout as shown in the submittal drawing.
2. Keep the slide in the frame.
3. Be sure that the frame is square, vertical and plumb.
4. Grout frame in place as required.
5. Be sure frame groove is clean and free of foreign material.

GATE WITH J-BULB SEALS

1. After installation in complete, check the clearance between the seal and the slide plate with a .004" feeler gauge
2. If the feeler gauge will not fit between the seal and the slide no adjustment is necessary.
3. If adjustment is necessary, loosen the J-bulb retainer bolts and move the seal against the slide until the rubber is slightly compresses. Then, tighten the bolts again.

MAINTENANCE:

Stop gates require no service or adjustment.

ALFALFA VALVES

INSTALLATION SUGGESTIONS:

TYPE 1 - WEB

Place grout on concrete riser, set valve. Add additional grout and trowel with laying glove to fill voids between web. After grout has dried, check and regrout any voids.

Caution - seat rings must be free of grout for at least 3/8" below surface. Valve should not be banded on outside when hook type hydrant will be used.

Note - this valve setting may be strengthened for use with higher heads or severe surges by tying reinforcing wire into web before grouting.

TYPE 2 - QUICK SETTING

Invert frame and fill cavity with heavy grout and/or place grout on top of riser pipe. Quickly turn frame over onto risers, rotating slightly to assure firm contact. Trowel inside edge. Clean seat and threads.

Note - The grouting cavity is large enough to accommodate most reinforced pipe as well as standard irrigation sizes.

TYPE 3 - FOR O.D. SIZE STEEL PIPE

Place on pipe and weld or braze. Preheating and slow cooling are recommended for fracture free attachment. An epoxy cement can also be used for attaching. Pipe should be clean (blast or wire brush) and care taken to leave no voids between pipe and frame. Frame may also be attached by drilling and bolting through, using a suitable mastic for the seal between pipe and frame.

TYPE 4 - FOR I.D. LOWHEAD PLASTIC PIPE

METHOD #1 INSTALLATION:

Press valve into inside of riser pipe and secure with two draw bands. Heat pipe if needed to allow valve spigot to enter pipe I.D.

METHOD #2 INSTALLATION:

Using #1950 or #10 I.P.S. two-part epoxy or equal, apply cement to outside surface of valve skirt and inside surface of riser. Press firmly into riser, rotating 1/4 turn.

TYPE CIP - "EASY MOUNT" FOR PLASTIC PIPE

(CIP-PIP for plastic irrigation pipe size pipe - CIP-IPS for iron pipe size plastic pipe)

INSTALLATION SUGGESTIONS:

Prime inside of plastic valve skirt and outside of pipe riser. Apply PVC cement to same surfaces and immediately press valve firmly onto riser, rotating a 1/4 turn as you set valve.

H-30FF, HD-30FF AND AH-30FF FLANGED GATE VALVES

INSTALLATION:

1. Utilizing studs and gaskets, mount the flanges to corresponding pipe flanges. On valves that accommodate flow in one direction only, be sure flow arrow on valve is properly oriented.

MAINTENANCE:

Grease zirk fitting on packing collar as needed. Do not overfill.

OPERATION:

1. Turn in direction of arrow on handwheel to open, opposite to close.

H-30-1 LINE GATE

1. Orient gate with the flow arrow (cast in the gate body) in proper relation to the direction of flow in the pipe.
2. Push gate hub over the outside of the pipe so that it is as nearly centered as possible, butting the stop ring on the inside of the hub against the end of the pipe. (Thrust blocking is recommended, especially on gates 24" and larger, to prevent settling of the gate and subsequent rupture of the seal between the gate and pipe.)
3. Supporting the gate firmly in place, apply a dry pack mortar mixture to the gap between the hub and pipe, making sure to seal all the way around, including the bottom of the pipe.
4. Repeat the above procedure for the opposite side of the gate, except pushing the pipe into the hub.
5. When dry, use a wetter mortar mixture to smooth over the dry pack joint to ensure a tight seal.